

Work like new

Website: www.flexispot.com

Tel: 1-855-585-5618

Address: 6475 Las Positas Rd. Livermore, CA 94551

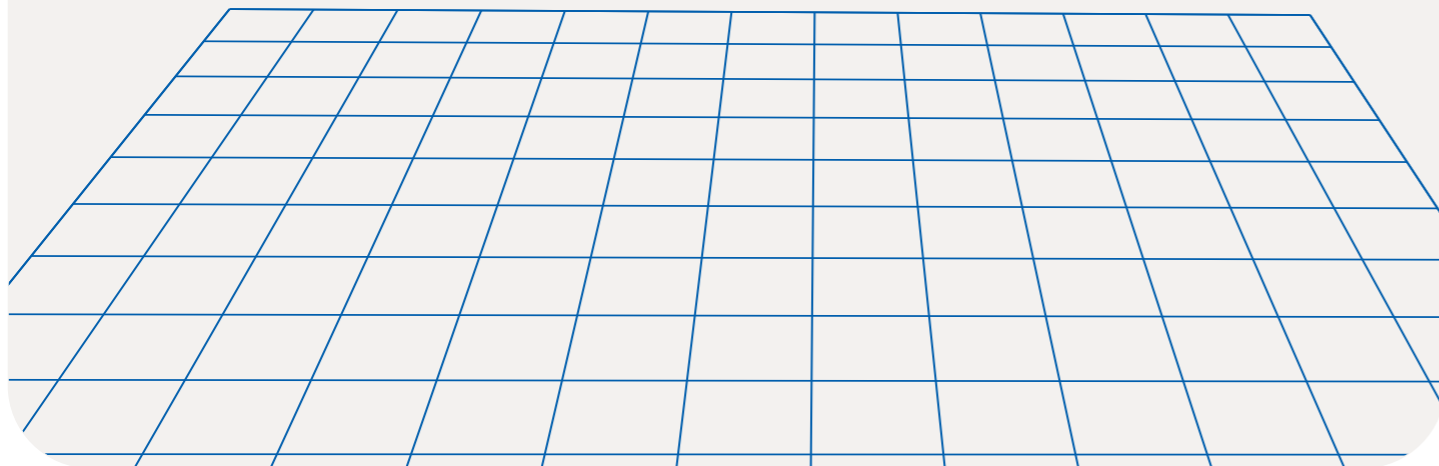

FlexiSpot

Item No.C7-foam-FT
User Manual

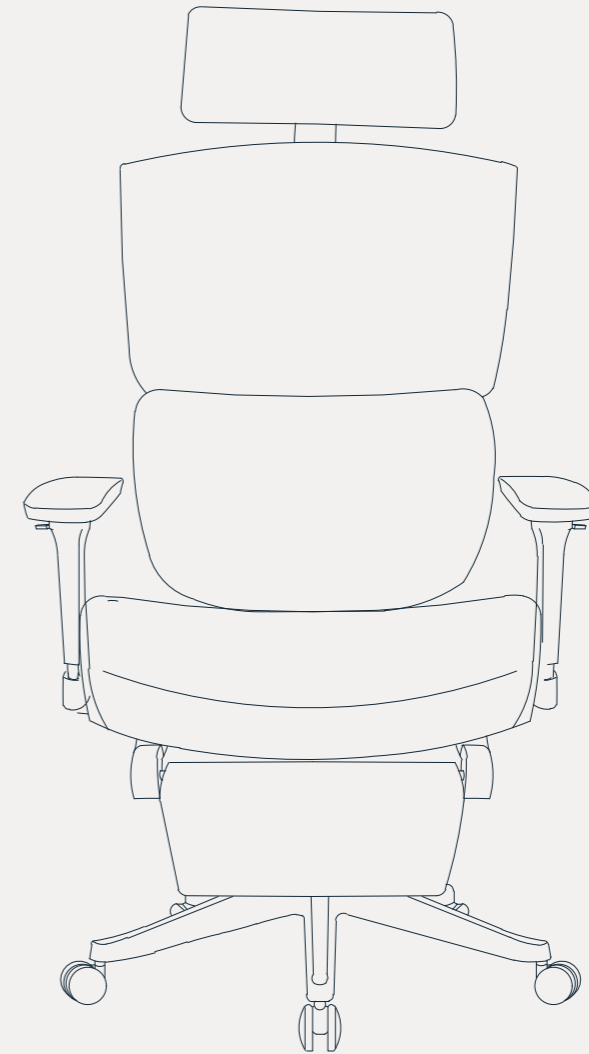



ASSEMBLY INSTRUCTION

BEFORE ASSEMBLY THIS PRODUCT, PLEASE READ THIS INSTRUCTIONS CAREFULLY

A 	B 	Cx5 	D 	I x4+1 (M8*40MM)
E 	F 	G 	H 	J x1+1 (M6*30MM)
				K x6+1 (M6*40MM)
				L x3+1 (M8*20MM)
				M x1

2

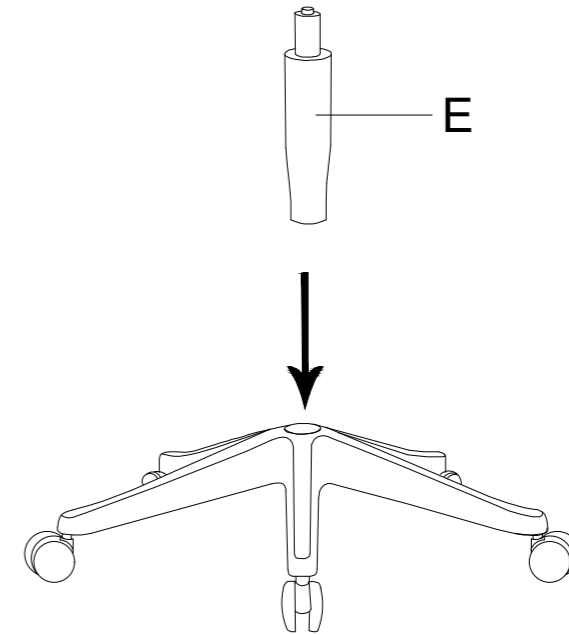

1

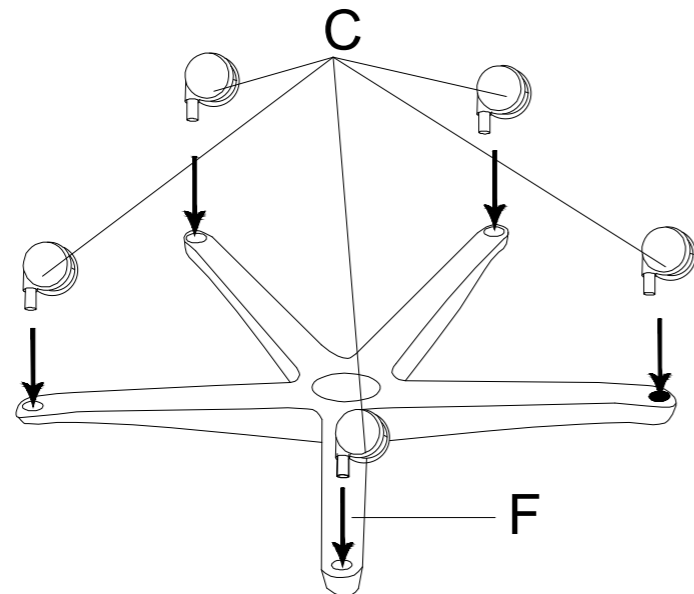

3

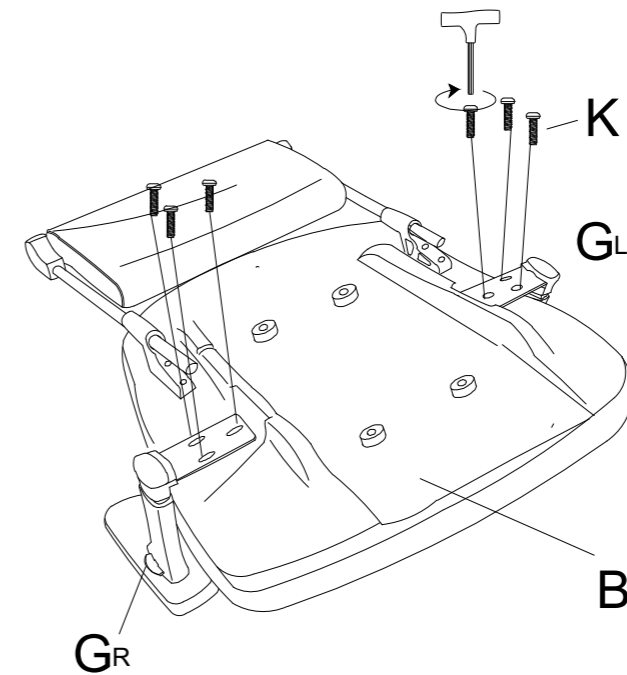

4

Push the handle and the mechanism to the end following the arrow direction at the same time, so the screw holes appear.

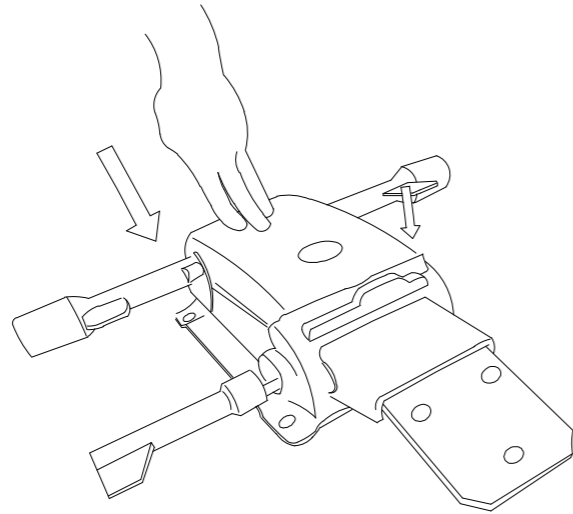

5

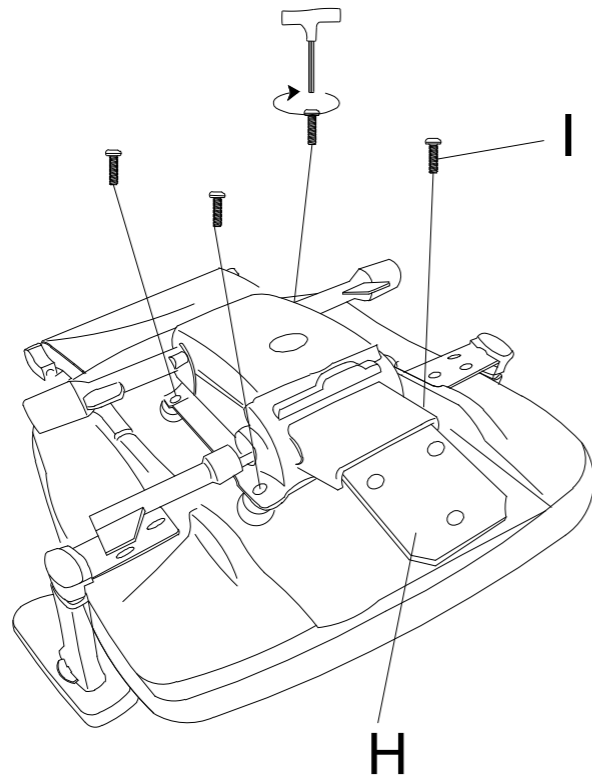

6

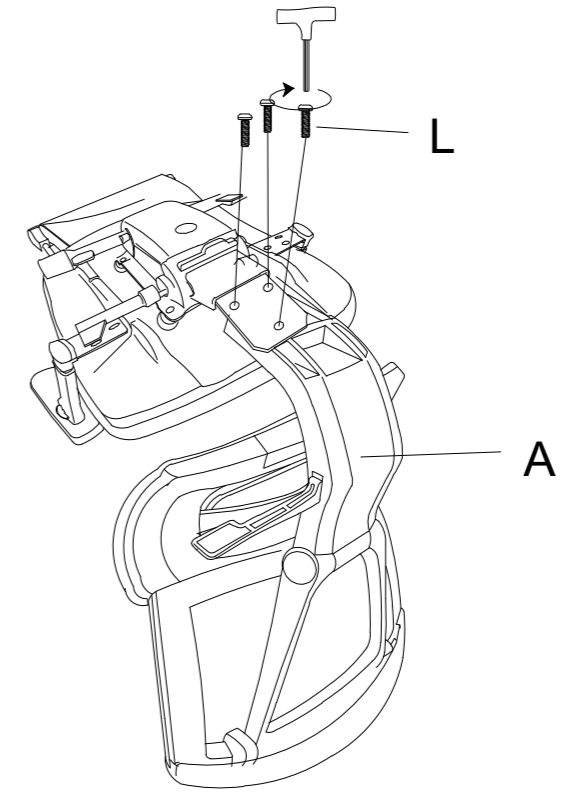

7

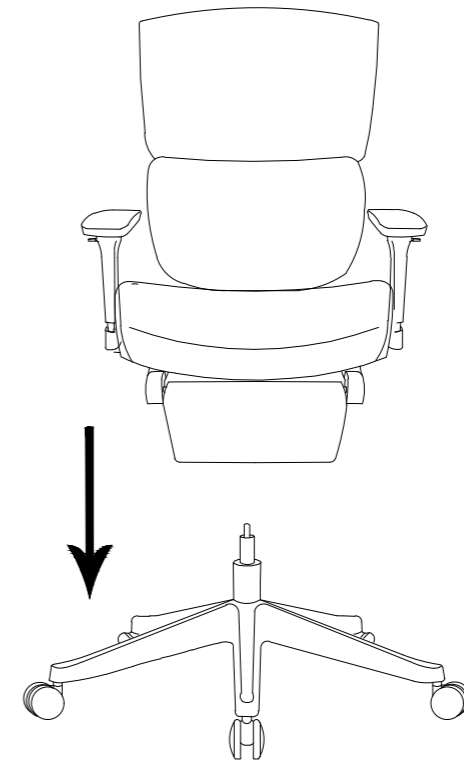

8

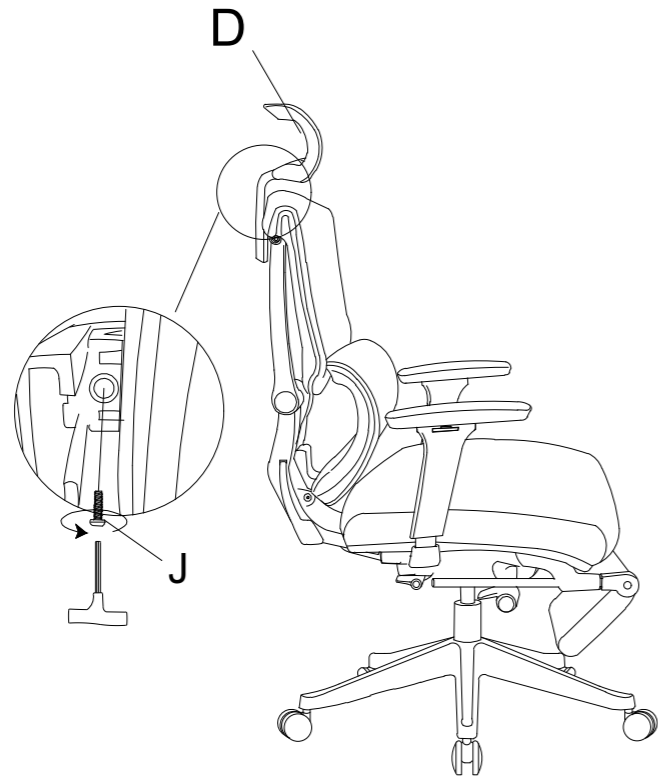

9

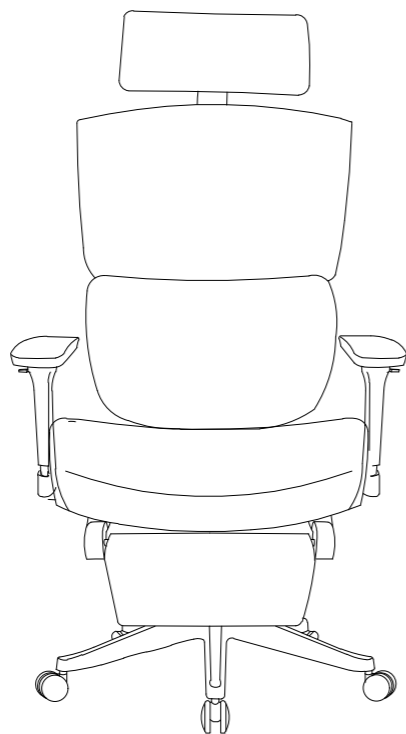

10

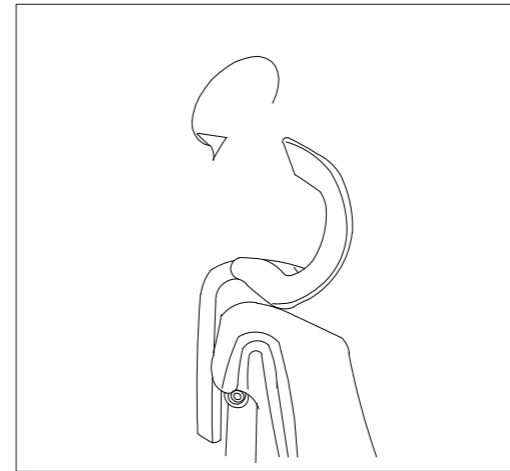

45° adjustment

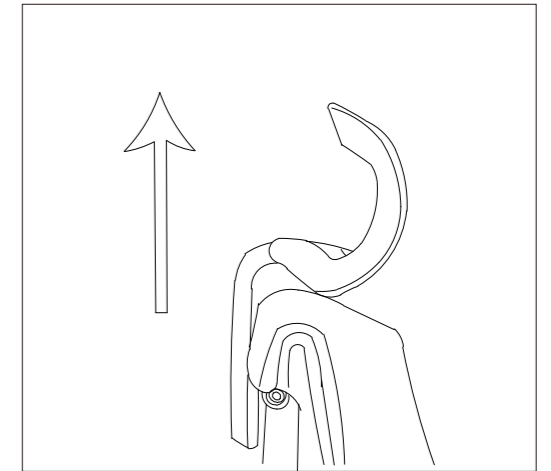

Up and down adjustment

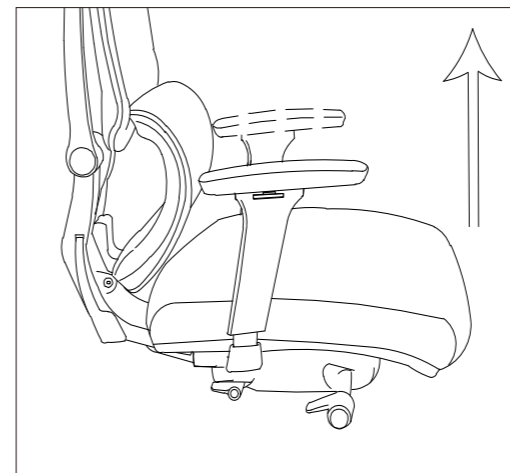

Armrest height adjustment

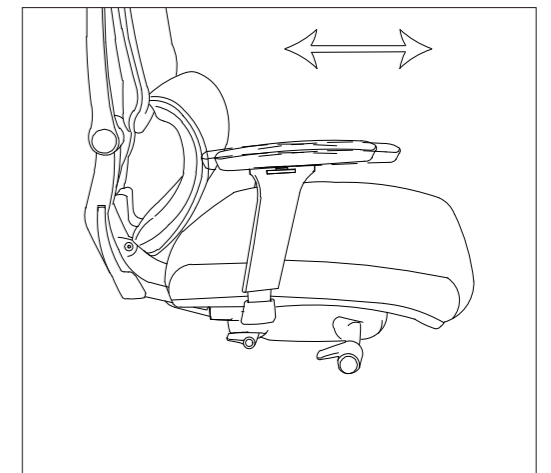

Forward and backward adjustment

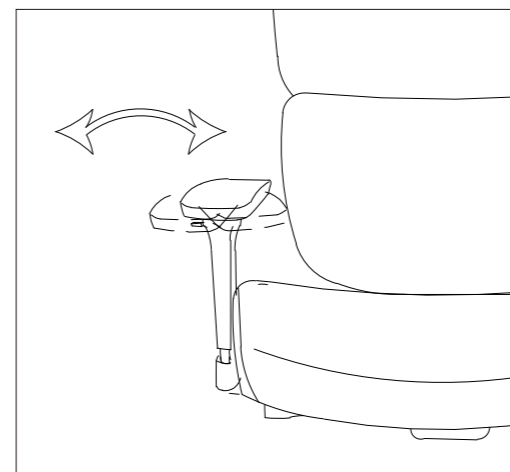

Rotation adjustment

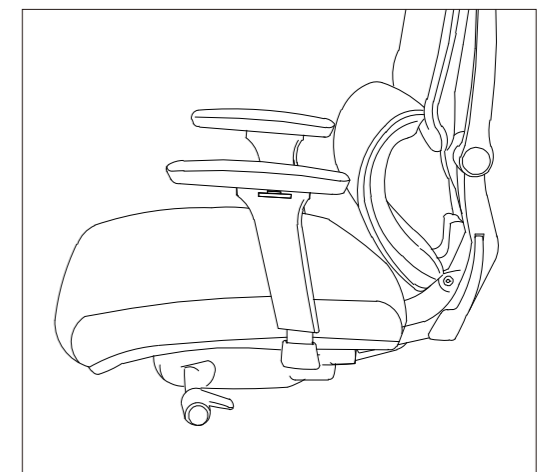

Seat cushion forward and backward adjustment



Handle up adjusts seat height

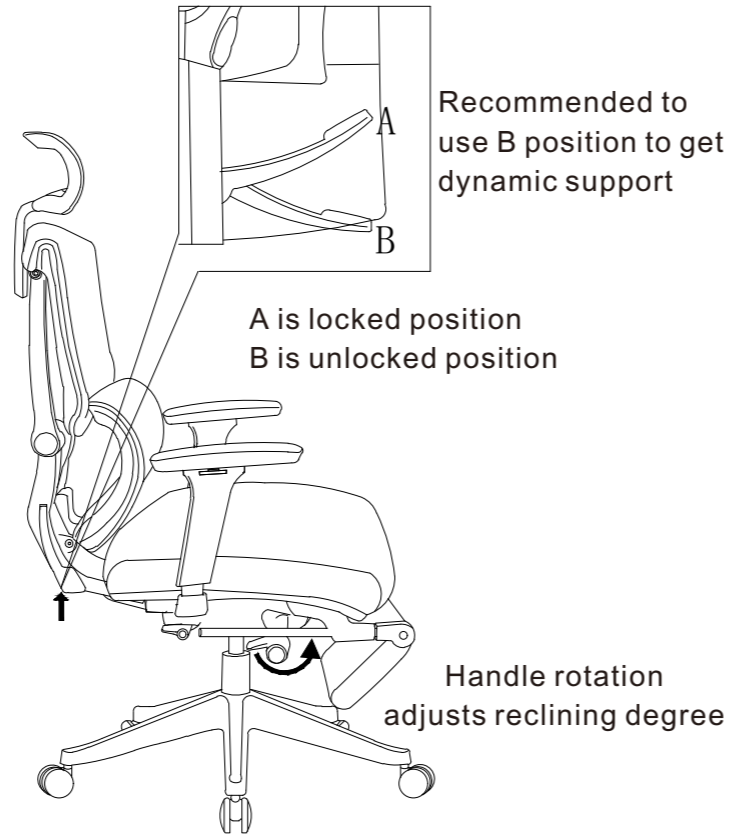

Recommended to use B position to get dynamic support

A is locked position
B is unlocked position

Handle rotation adjusts reclining degree

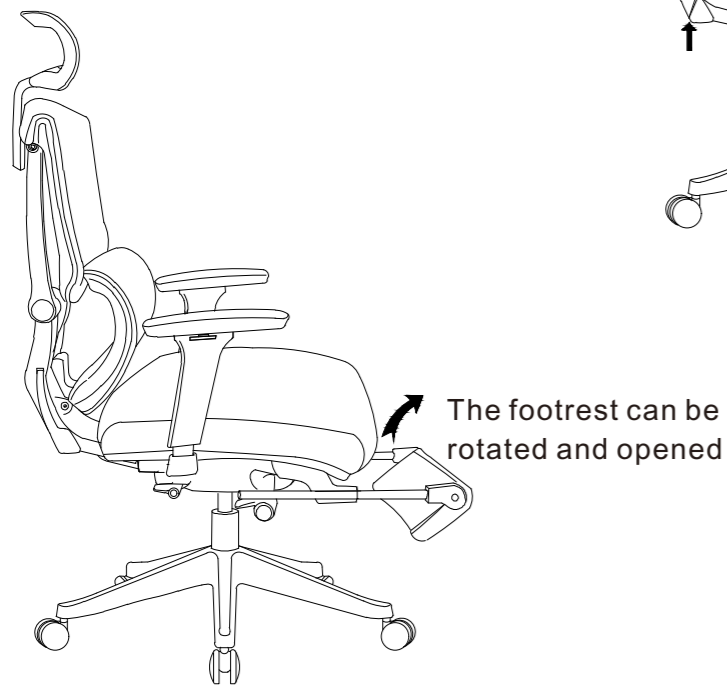

The footrest can be rotated and opened

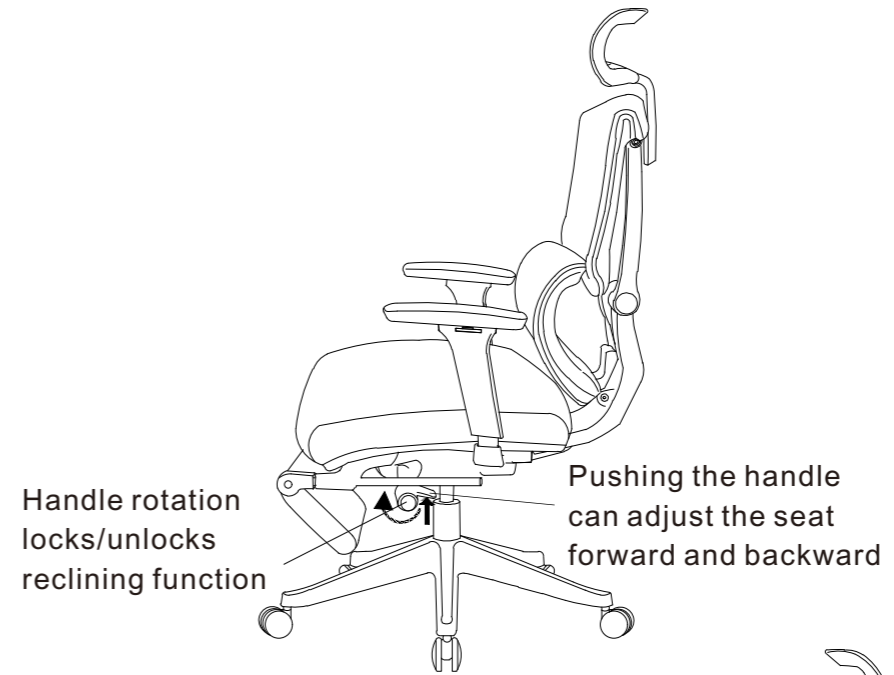

Handle rotation locks/unlocks reclining function

Pushing the handle can adjust the seat forward and backward

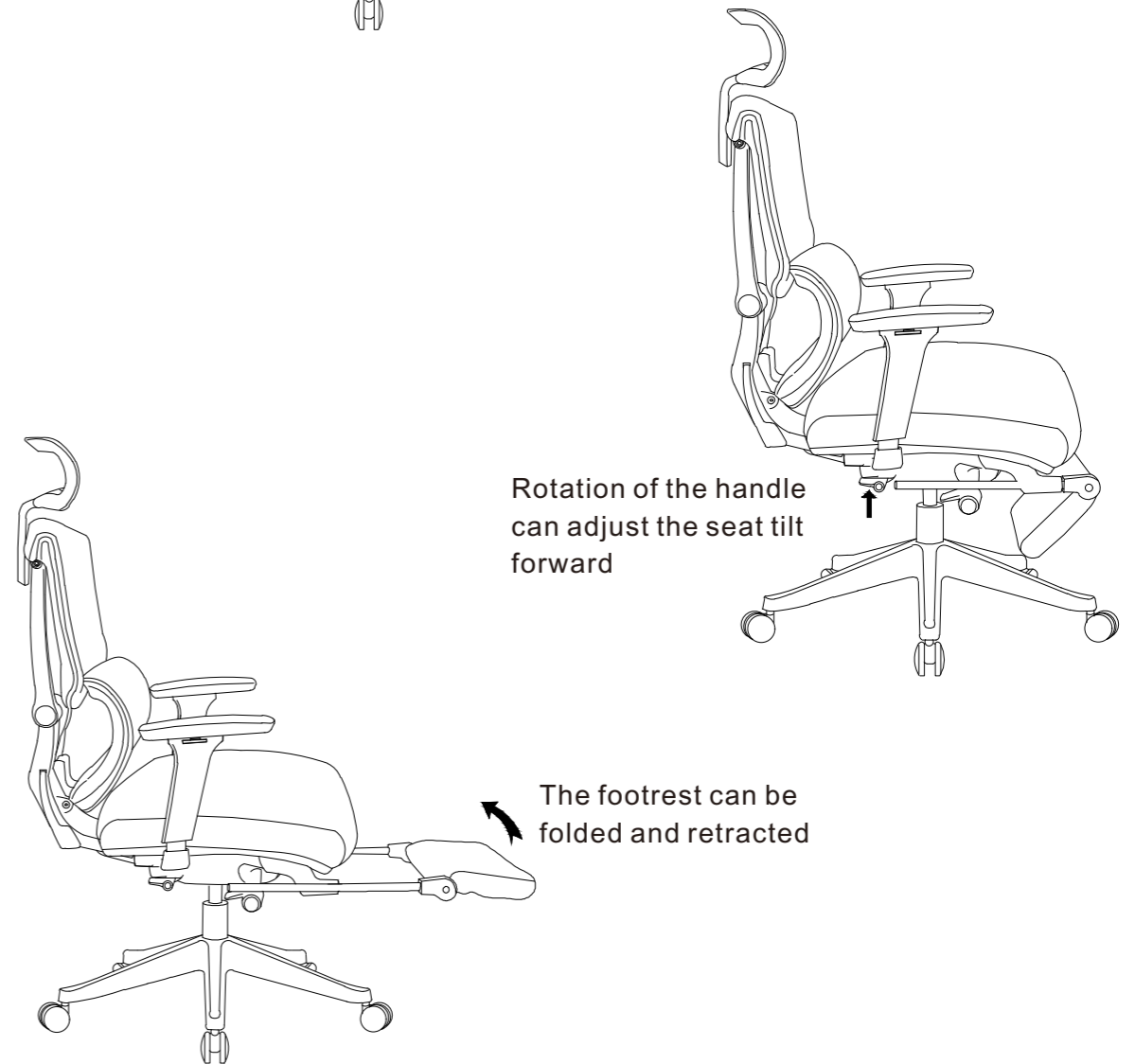

Rotation of the handle can adjust the seat tilt forward

The footrest can be folded and retracted

This limited warranty offered by FlexiSpot covers defects in material or workmanship in new FlexiSpot products. This warranty extends to the original purchaser only and is non-transferable. Only consumers purchasing FlexiSpot products from authorized FlexiSpot retailers or resellers may benefit from our limited warranty.

What is Covered?

The FlexiSpot limited warranty covers our products against defects in material or workmanship as follows:

·FlexiSpot Height Adjustable Desk Frames

All height-adjustable desks feature a 5-year warranty for the frame & motor and a 2-year warranty for the controller, switch, electronics and other mechanisms.

·FlexiSpot Sit-Stand Desktop Workstations

All sit-stand desktop workstations feature a 5-year warranty for the frame & desktop and a 3-year warranty for the gas spring system and other mechanisms.

· FlexiSpot Office Chairs

FlexiChair C7 & C7 Pro feature a 5-year warranty for chair body, and other mechanisms.

·FlexiSpot Desk Bikes

All desk bikes and parts, including the frame, electronics, and other mechanisms, feature a 1-year warranty.

·FlexiSpot Mini Steppers

All Mini Steppers feature a 3-year warranty.

·FlexiSpot Monitor Mounts

All monitor mounts and parts, including arms, gas spring systems and other mechanisms, feature a 5-year warranty.

What are your Remedies?

FlexiSpot will replace at no charge to the consumer the defective parts only or, at FlexiSpot's option, replace any product or part of the product that is defective because of improper workmanship and/or material, under normal installation, use, service and maintenance. If FlexiSpot is unable to provide a replacement and repair is not practical or cannot be completed in a timely fashion, FlexiSpot may elect to refund the purchase price in exchange for the return of the product. In the rare event that your FlexiSpot product is defective, we will provide you with a replacement item shipped at no cost to you within the continental United States. The shipping method for replacement products is FedEx Ground, but expedited shipping is available if you choose to pay the additional expense. In addition, you will need to pay the shipping costs if any products need to be shipped to you at an address outside the continental United States.

REPAIR OR REPLACEMENT (OR, IN LIMITED CIRCUMSTANCES, REFUND OF THE PURCHASE PRICE) AS PROVIDED UNDER THIS WARRANTY IS THE EXCLUSIVE REMEDY OF THE PURCHASER. FLEXISPOT NEITHER ASSUMES NOR AUTHORIZES ANY PERSON TO CREATE FOR ANY OTHER OBLIGATION OR LIABILITY IN CONNECTION WITH THIS PRODUCT.

What is Not Covered?

Our limited warranty does not cover any problem that is caused by:

1. Conditions, malfunctions or damage not resulting from defects in material or workmanship.
 2. Conditions, malfunctions or damage resulting from normal wear and tear, improper installation, improper maintenance, misuse, abuse, negligence, accident or alteration.
 3. Accessories, connected materials and products, or related products not manufactured by FlexiSpot.
 4. Conditions, malfunctions or damage resulting from failure to follow the instructions and guidelines relating to the product's intended use.
- Our limited warranty is void if a product is returned with removed, damaged or tampered labels or any alterations (including removal of any component or external cover).

How to File a Claim?

In order to receive the benefit of our limited warranty, you need to process your claim in compliance with the terms of this limited warranty and follow proper return procedure. To request warranty service, please contact customer service via email at contact@FlexiSpot.com or toll free at 1-855-585-5618. You will need to provide the sales receipt or other evidence of the date and place of purchase for your FlexiSpot product.

Implied Warranties and Limitation of Damages

EXCEPT TO THE EXTENT PROHIBITED BY APPLICABLE LAW, ALL IMPLIED WARRANTIES (INCLUDING WARRANTIES OF MERCHANTABILITY AND FITNESS FOR A PARTICULAR PURPOSE) SHALL BE LIMITED IN DURATION TO THE DURATION OF THIS WARRANTY, AND FLEXISPOT SHALL NOT BE LIABLE FOR ANY INCIDENTAL, INDIRECT, SPECIAL, OR CONSEQUENTIAL DAMAGES, INCLUDING BUT NOT LIMITED TO LOSS OF PROFITS OR REVENUE, RESULTING FROM ANY BREACH OF EXPRESS OR IMPLIED WARRANTY OR CONDITION, OR UNDER ANY OTHER LEGAL THEORY, EVEN IF FLEXISPOT HAS BEEN ADVISED OF THE POSSIBILITY OF SUCH DAMAGES. Some jurisdictions do not allow limitations on the duration of an implied warranty or the exclusion or limitation of special, indirect, incidental or consequential damages, so the above limitations or exclusions may not apply to you.

Governing Law

This Warranty shall be governed by the laws of the State of California, USA, without giving effect to any conflict of laws principles that may provide the application of the law of another jurisdiction.

How State Law Applies

This Warranty gives you specific legal rights, and you may also have other rights which vary from state to state.