

# Work like new

Website: [www.flexispot.com](http://www.flexispot.com)

Tel: 1-855-585-5618

Address: 6475 Las Positas Rd. Livermore, CA 94551

# FlexiSpot

Item No. E2B/E2W/E2S  
User Manual

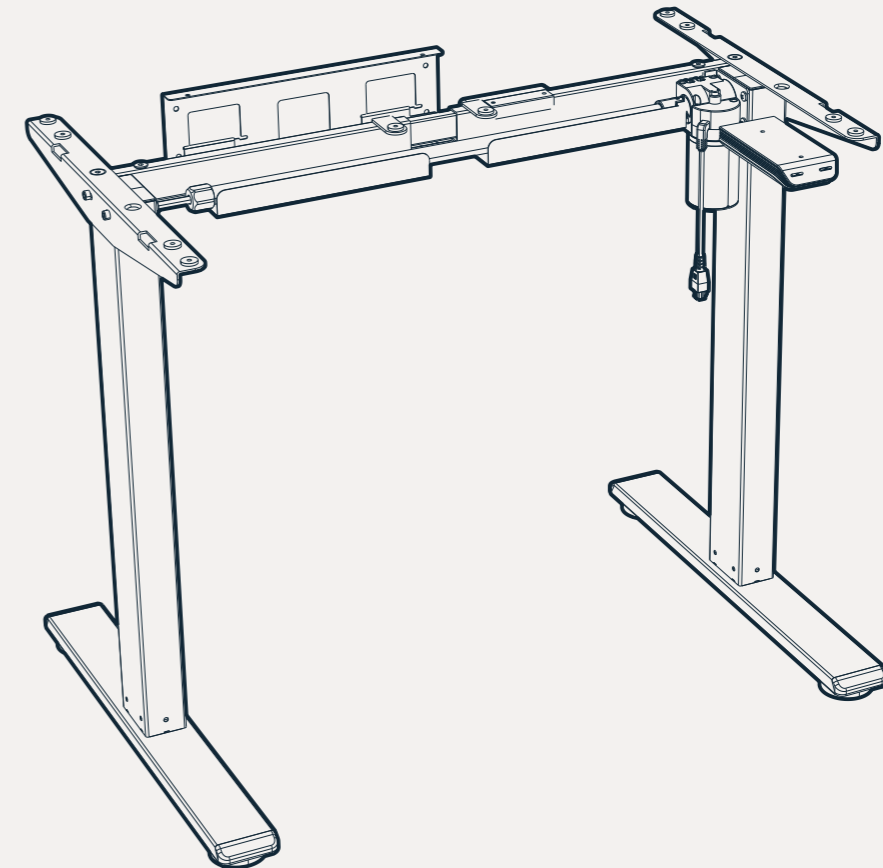

# Specifications

Max. Static Load	187 lbs (85kg)
Max. Speed	1"/s
Input Voltage	100 - 240 V
Min. Height	28" (710 mm)
Max. Height	47.6" (1210 mm)
Desktop Size	39.3" - 63"(1000 -1600 mm) in width and 19.7" - 31.5"(500 -800 mm) in depth
Duty Cycle	10% (Working 2 minutes then stop 18 minutes)
Working Temperature	32° - 104° F

# Assembly Notes

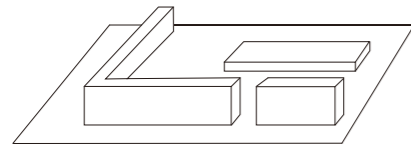

Installation need be done on a carpet to prevent scratches.

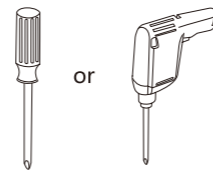

Installation will require a Phillips screwdriver or pistol drill.

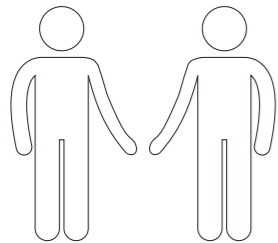

Installation must be done by at least two people.

# Product List

## Accessory Package

Figures shown are for reference only. Please contact customer service if there are any accessory or tools missing.

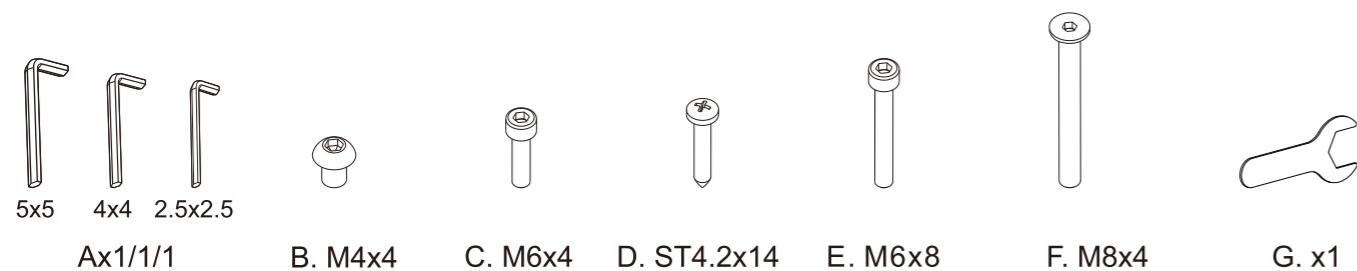

# Parts Included

No.	Part	No.	Part
①	Desk Foot x 2	⑨	Adapter Holder x 1
②	Lifting Column (Left) x 1	⑩	Keypad x 1
③	Lifting Column with Motor (Right) x 1	⑪	Power Cord x 1
④	Support Plate x 2	⑫	Patch Cord x 1
⑤	Transmission Rod x 1	⑬	Cable Tie x 4
⑥	Crossbeam x 1	⑭	Screw of Keypad (ST4.2) x 2
⑦	Baffle x 2	⑮	Cable Management Holder x 1
⑧	Adapter x 1	⑯	Cable Management x 1

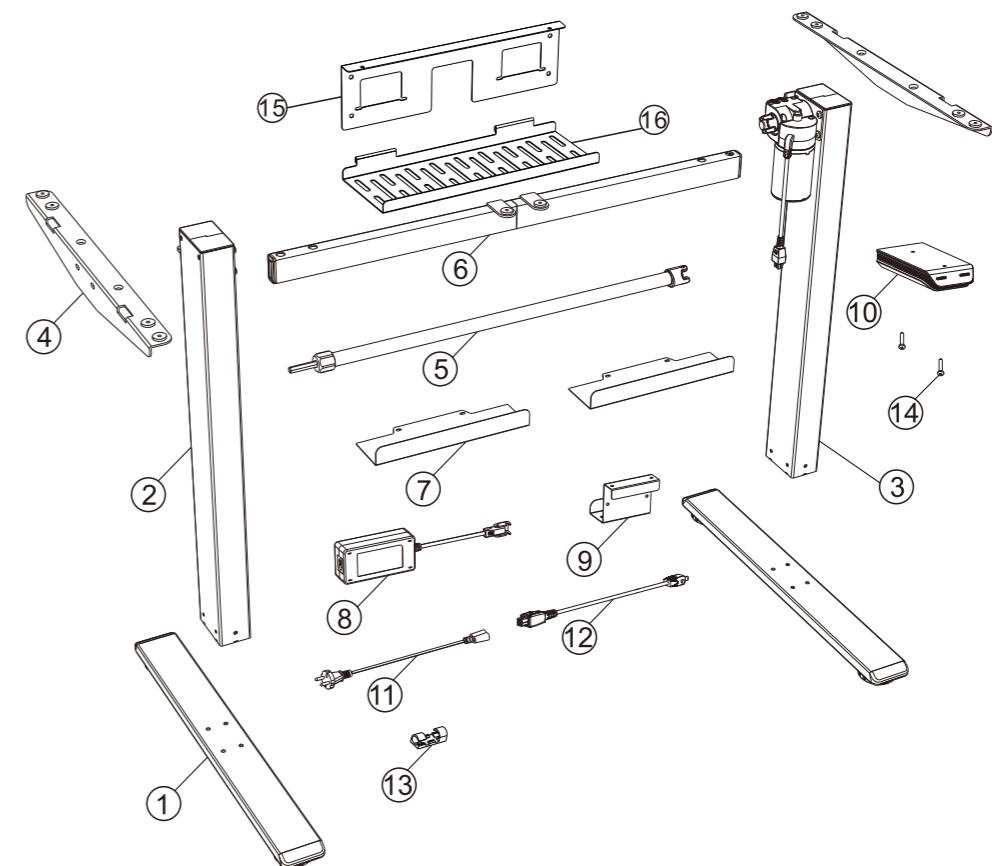

# Assembly Steps

## Step 1: Install the Desk Feet

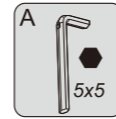
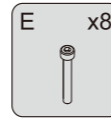
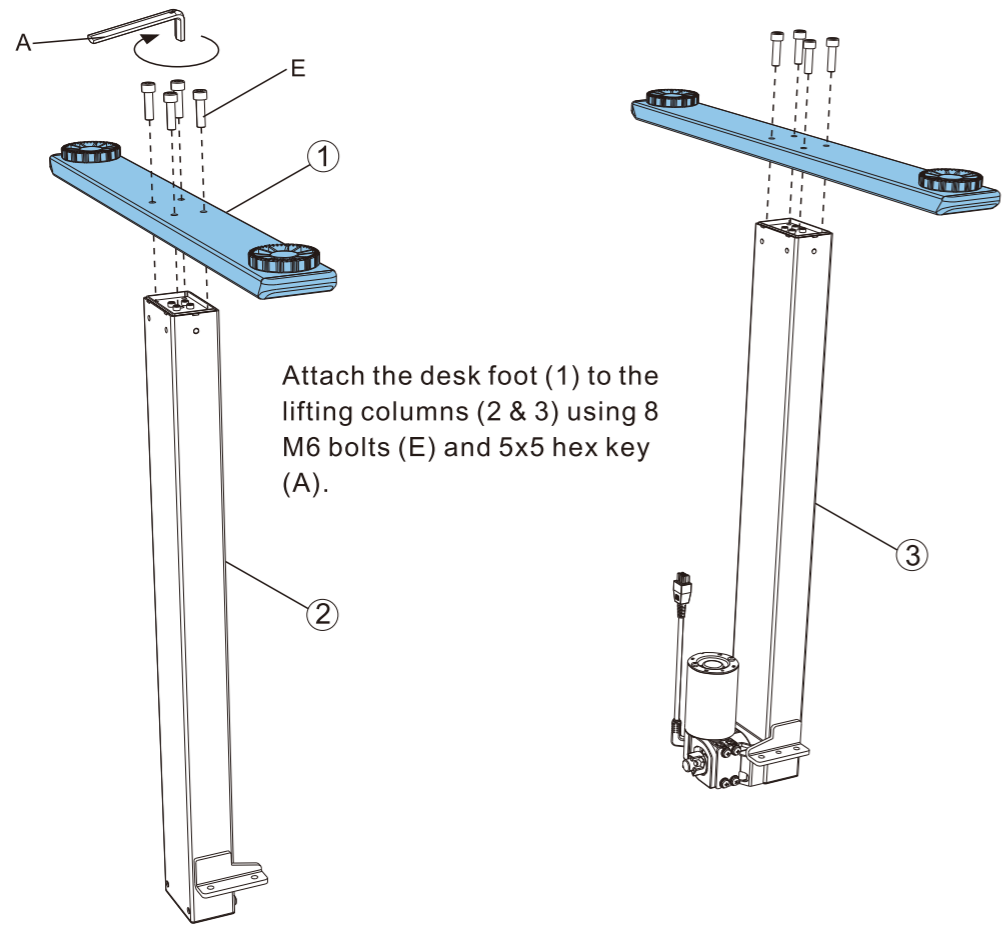

Attach the desk foot (1) to the lifting columns (2 & 3) using 8 M6 bolts (E) and 5x5 hex key (A).

## Step 2: Stretch the Crossbeam

Loosen the 4 bolts in the crossbeam (6) with 4x4 hex key (A), then stretch the crossbeam out.

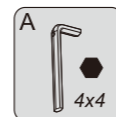
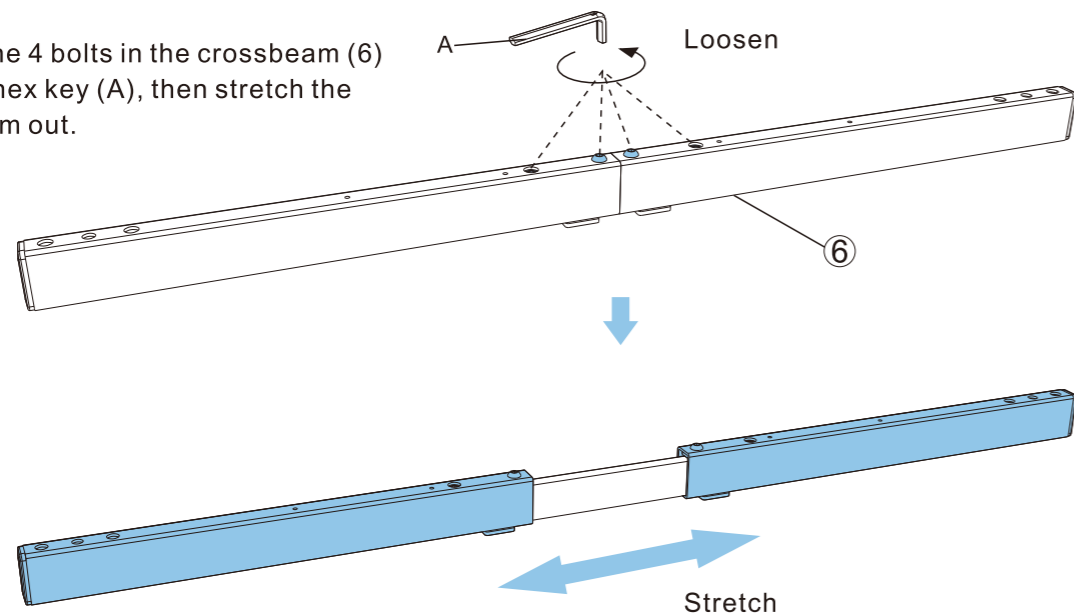

## Step 3: Install the Crossbeam

Attach the crossbeam to the lifting columns (2 & 3) with the M8 bolts (F) and tighten them down with the 5x5 hex key (A).

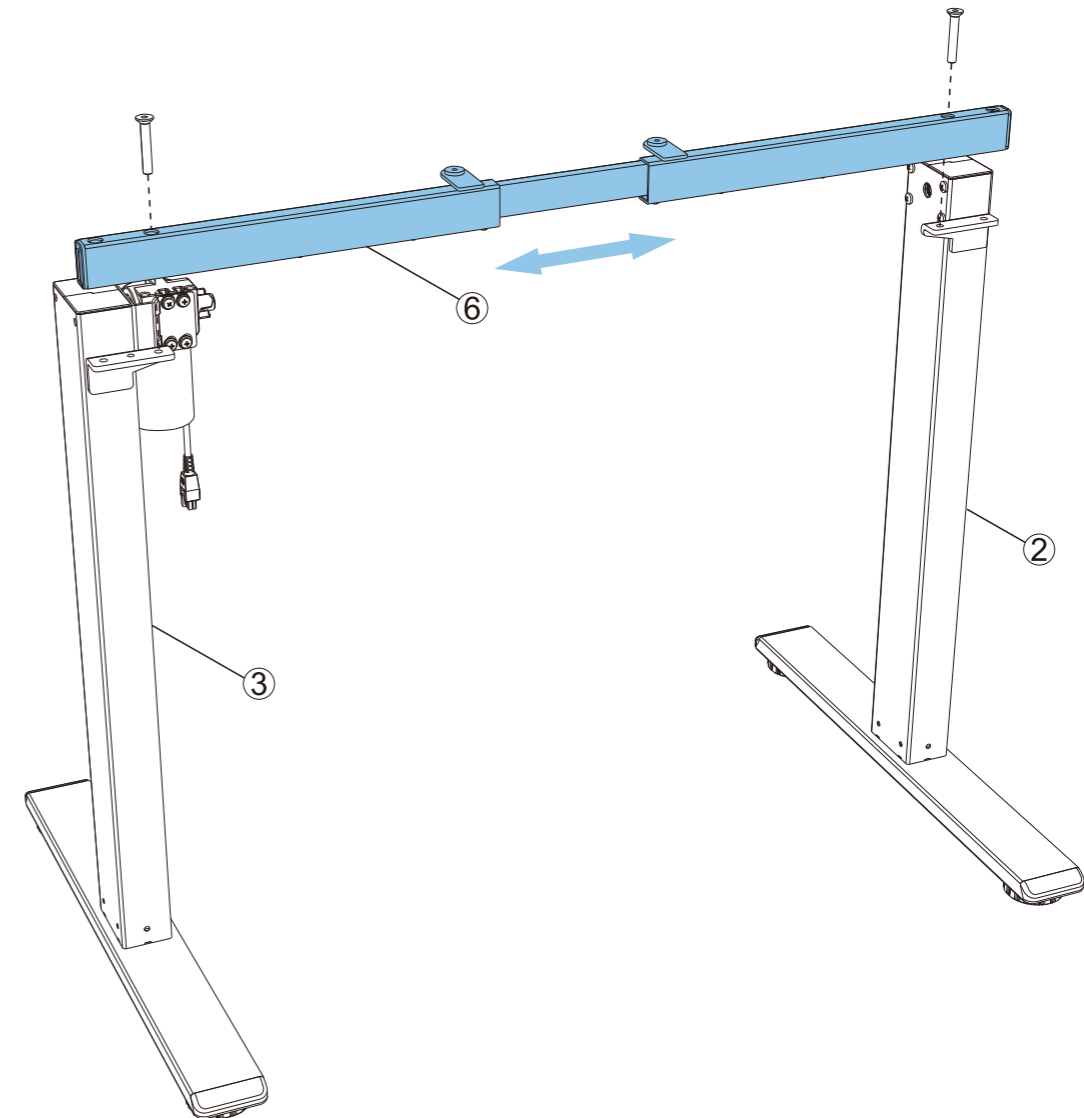
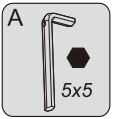
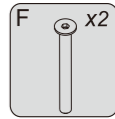
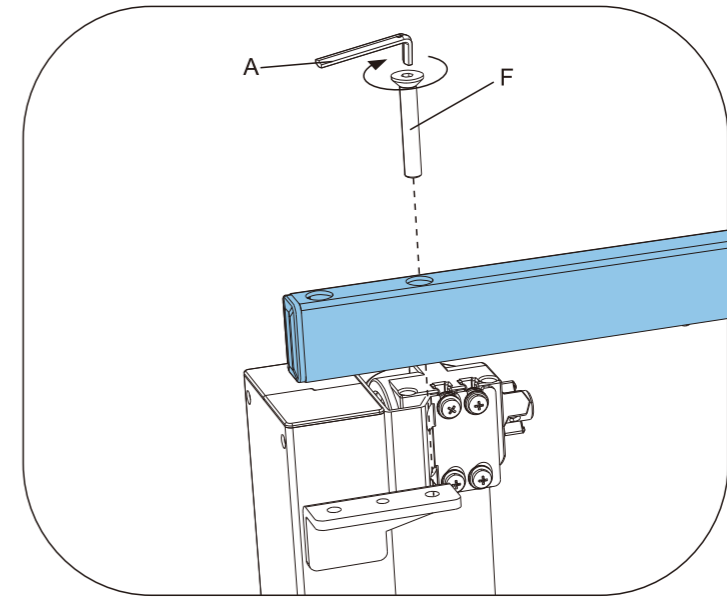

## Step 4: Install the Transmission rod

To install the transmission rod (5), first slot it into lifting column (2) and loosen the hex bolt (Figure. 1). Extend the transmission rod and slot it into the motor on lifting column (3), then tighten it down with the included 2.5x2.5 hex key (A) (Figure. 2)

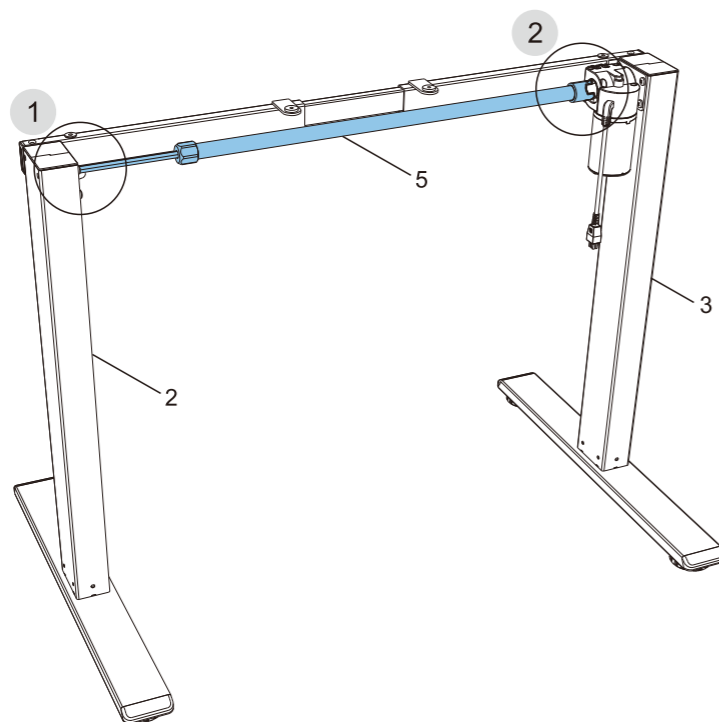
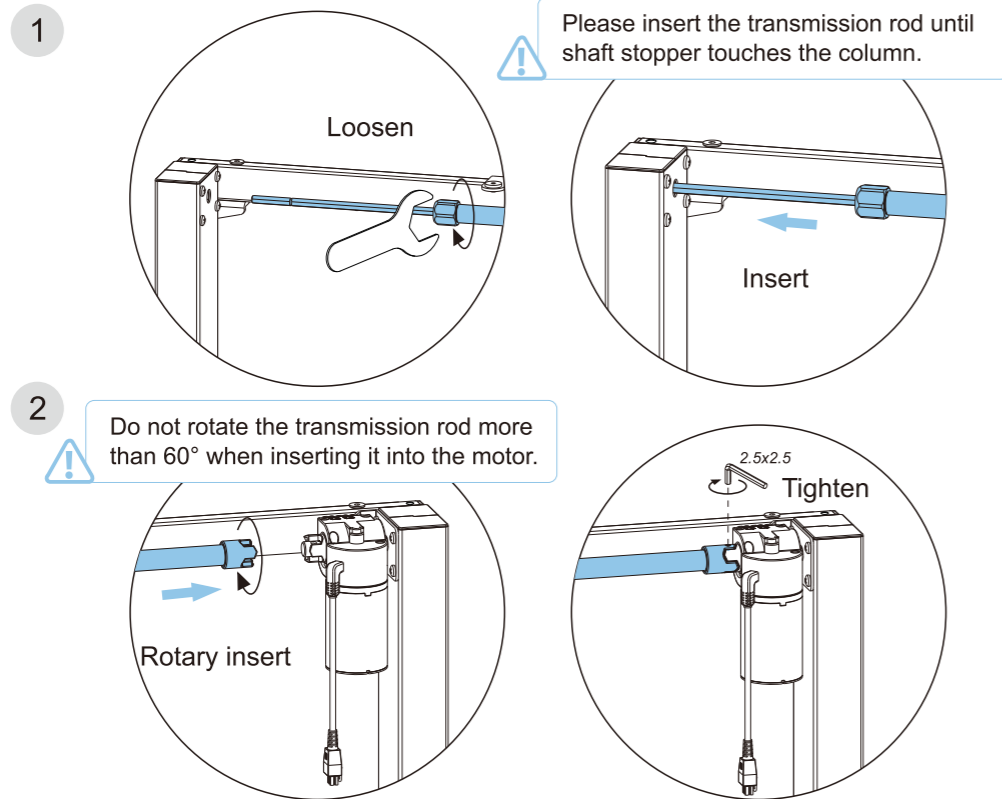
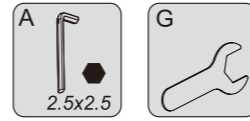

## Step 5: Install the Support Plates

Attach the support plates(4) to the lifting columns (2&3) using M6 bolts(C) and M8 bolts(F). Tighten with 5X5 hex key (A).

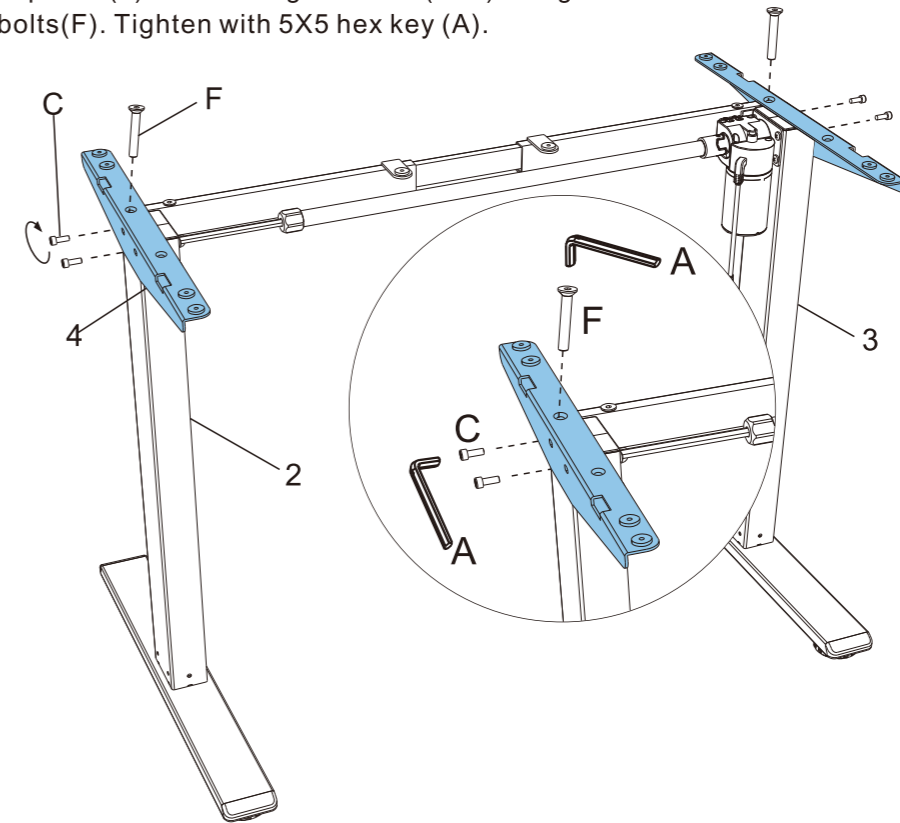
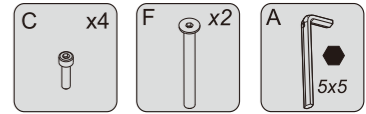

## Step 6: Install the Adapter Holder

Put the frame upside down on the underside of the desktop.

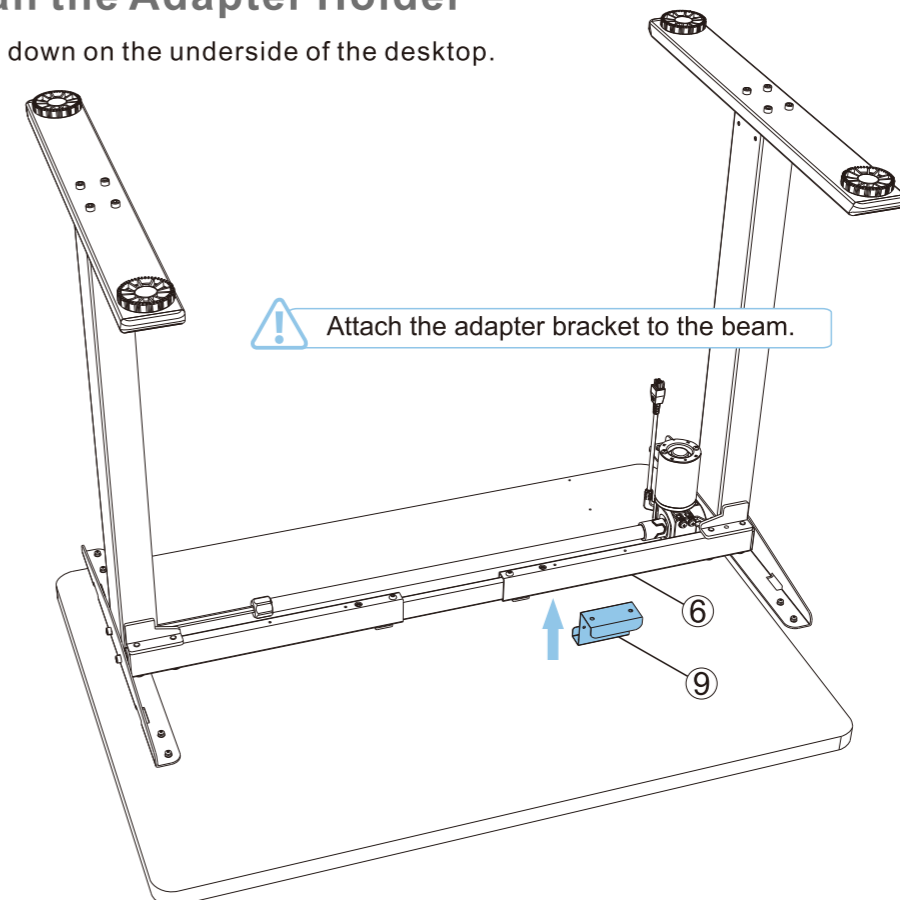

## Step 7: Install the Desktop

Adjust the length of transmission rod and crossbeam, carefully line up the frame to match the pre-drilled holes. Attach the frame to the desktop using ST4.2 screws (D) and tighten with drill.

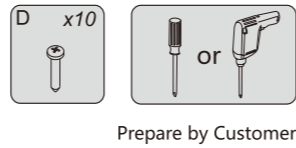

Install the screws in the following sequence: ● ➡ ■

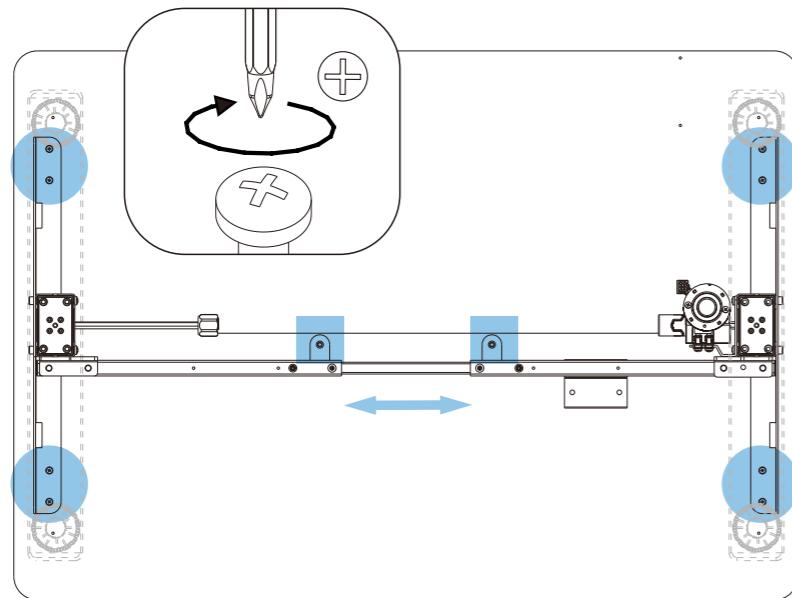

## Step 8: Tighten the Crossbeam and Transmission Rod

Tighten down the 4 bolts in the crossbeam with the 4x4 hex key (A), and the hex bolt in the middle of the transmission rod with the wrench (G).

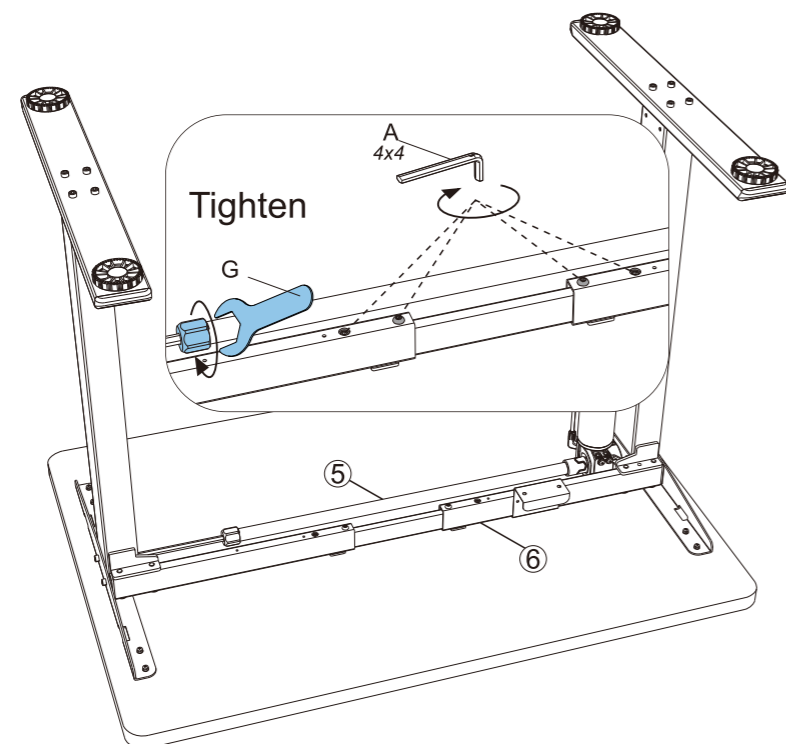
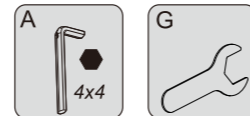

## Step 9: Install the Keypad

Install the keypad (10) with ST4.2 screw (14).

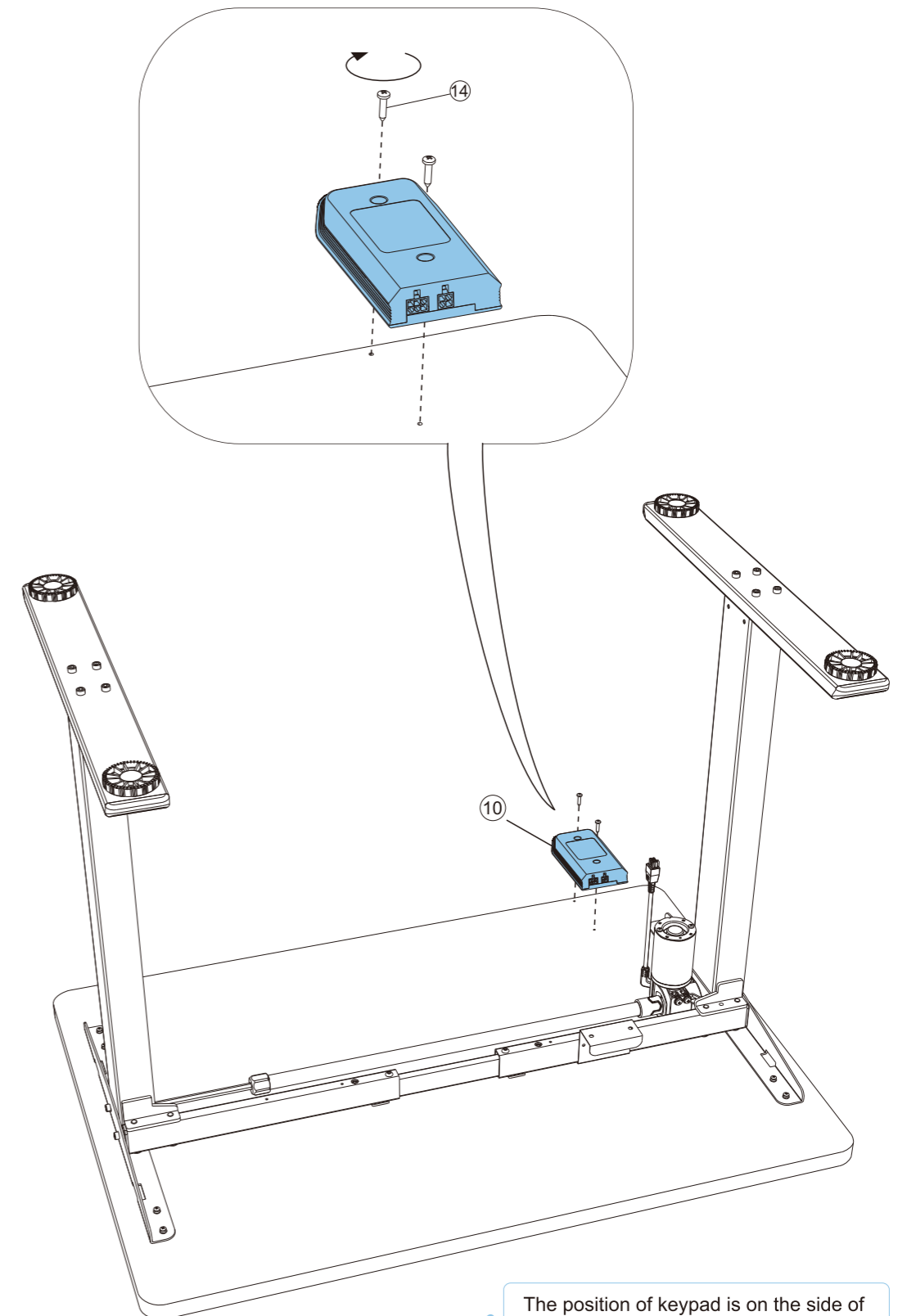
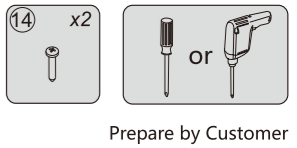

 The position of keypad is on the side of the lifting column with the motor.

## Step 10: Install the Adapter

Insert the adapter (8) into the holder (9).

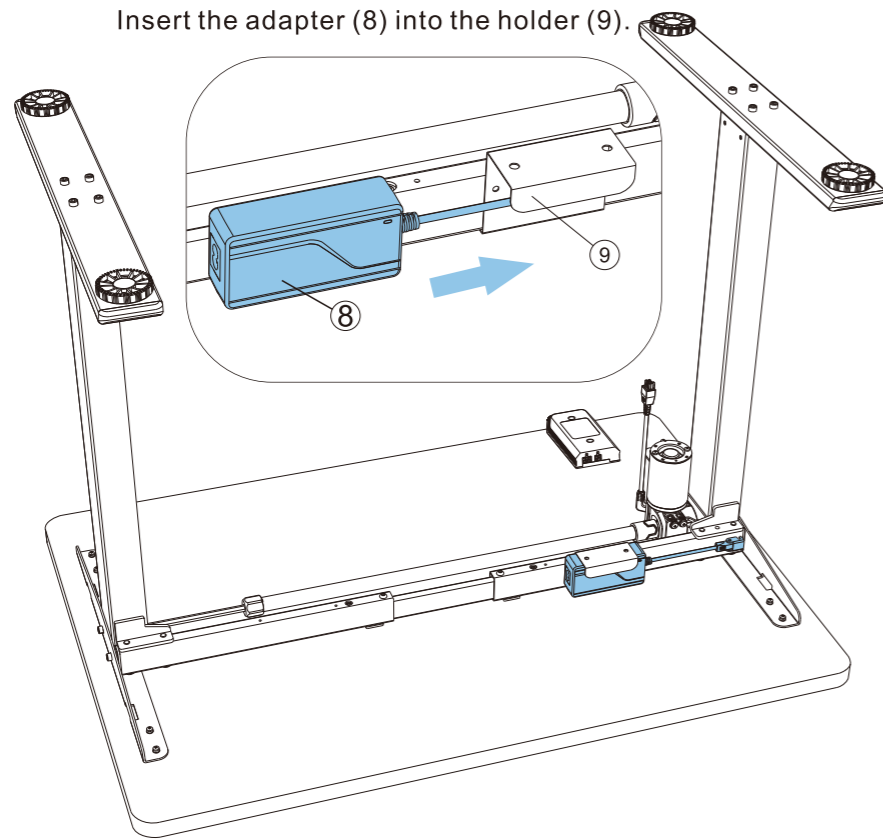

## Step 11: Install the Baffle

Attach the baffle (7) to the crossbeam using M4 bolts (B) and tighten with 2.5x2.5 hex key (A).

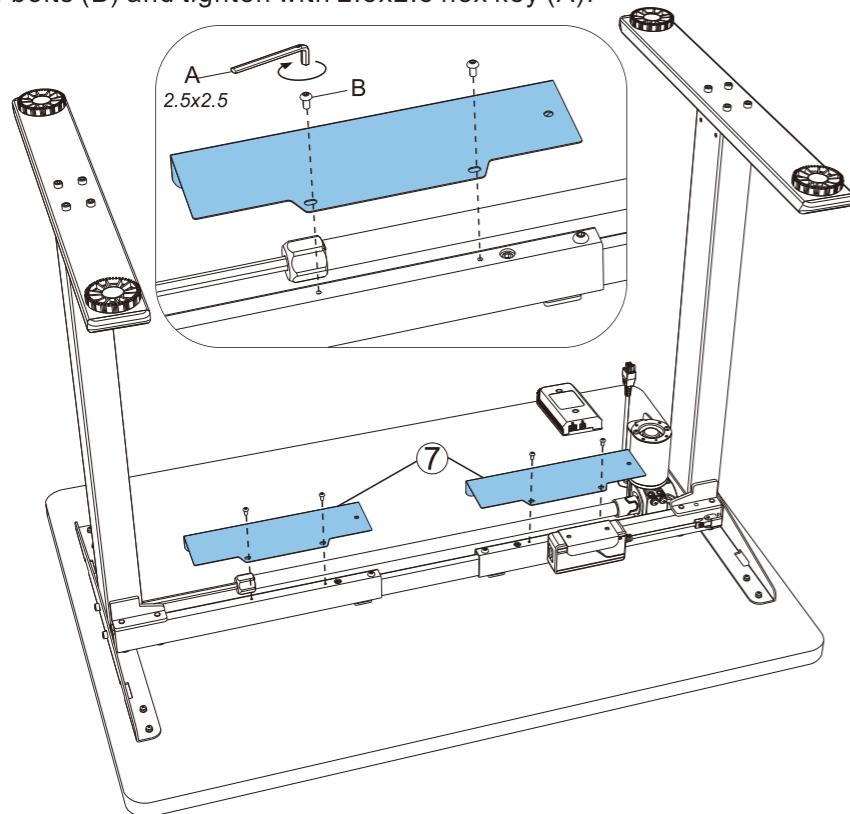
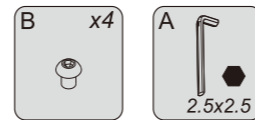

## Step 12: Install and Sort out Power Cord

Connect the power cord (11) to the adapter (8) as shown on the picture.

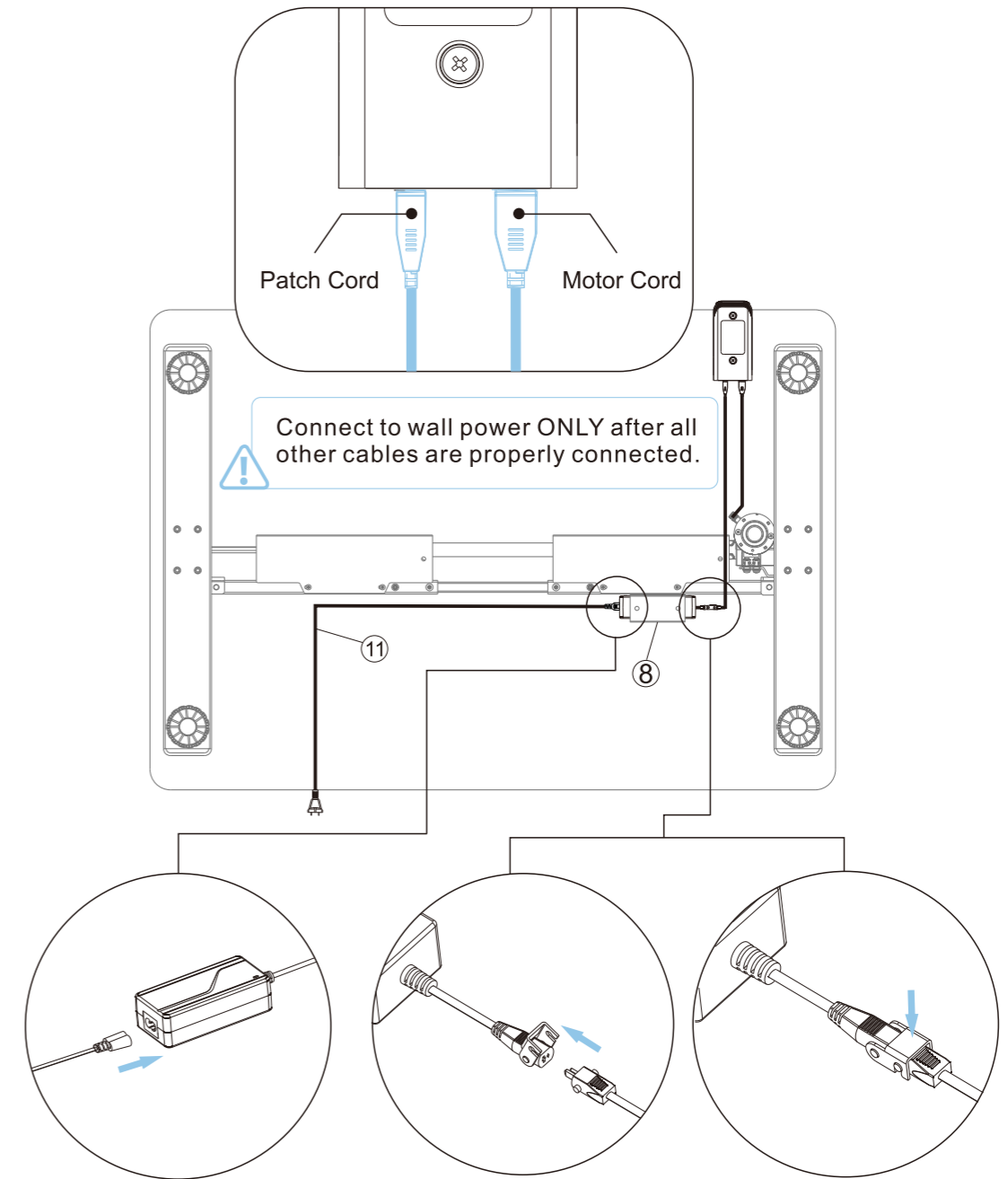

Open up

Sort out cords

Buckle up

13 x4

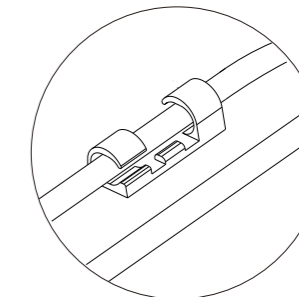
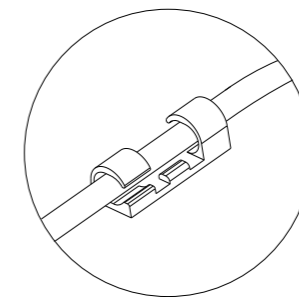
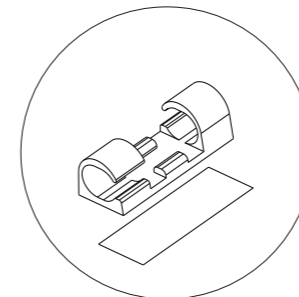

The cable tie (13) can be used to fasten the cables to the desktop and keep the cables organized.

### Step 13: Install the Cable Management Holder

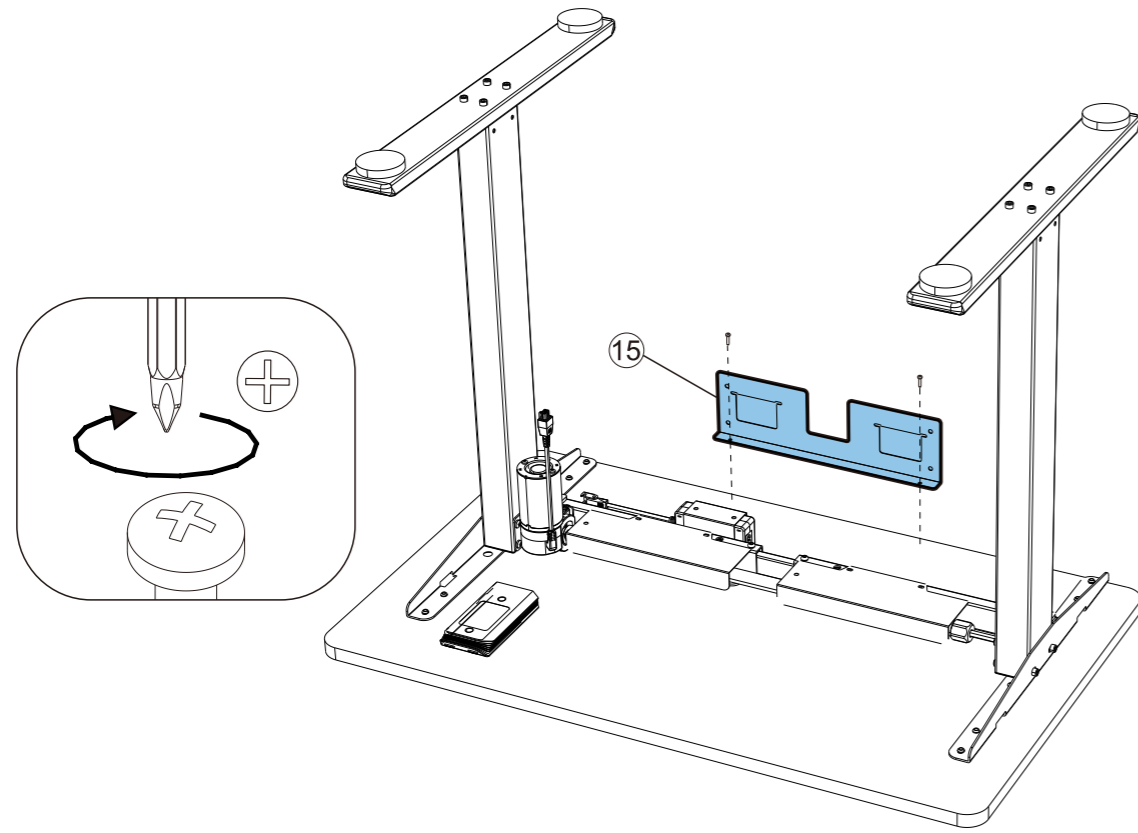
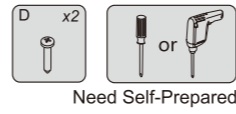

### Step 15: Install the Cable Management

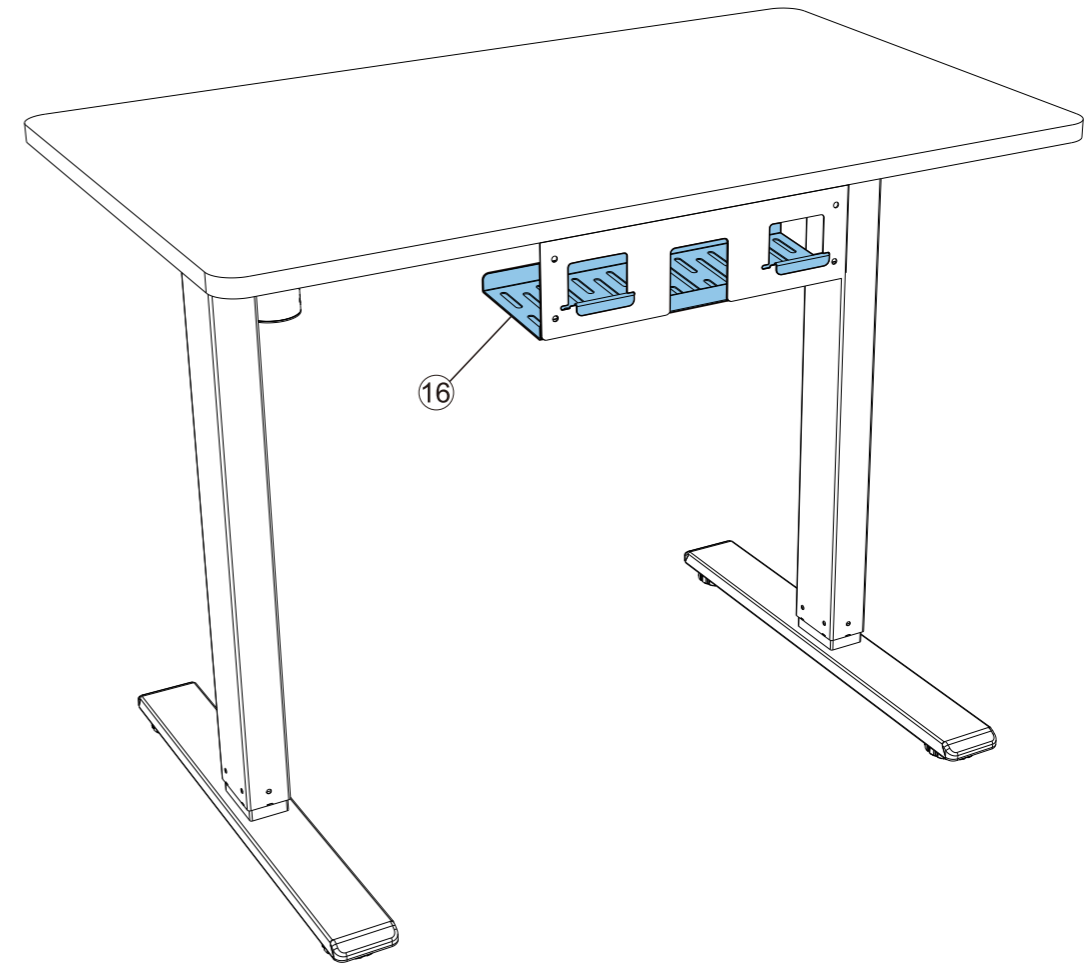

### Step 14: Turn Over the Desk

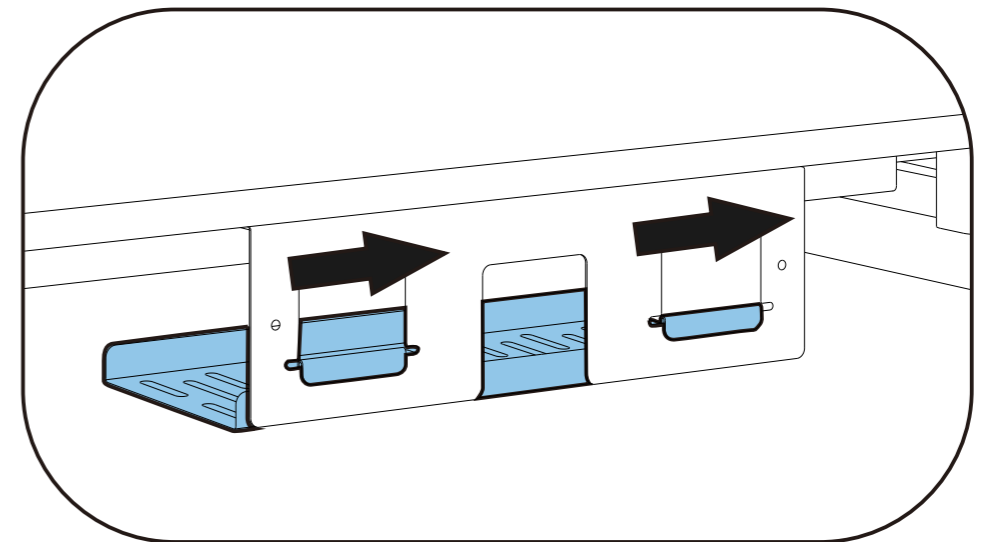
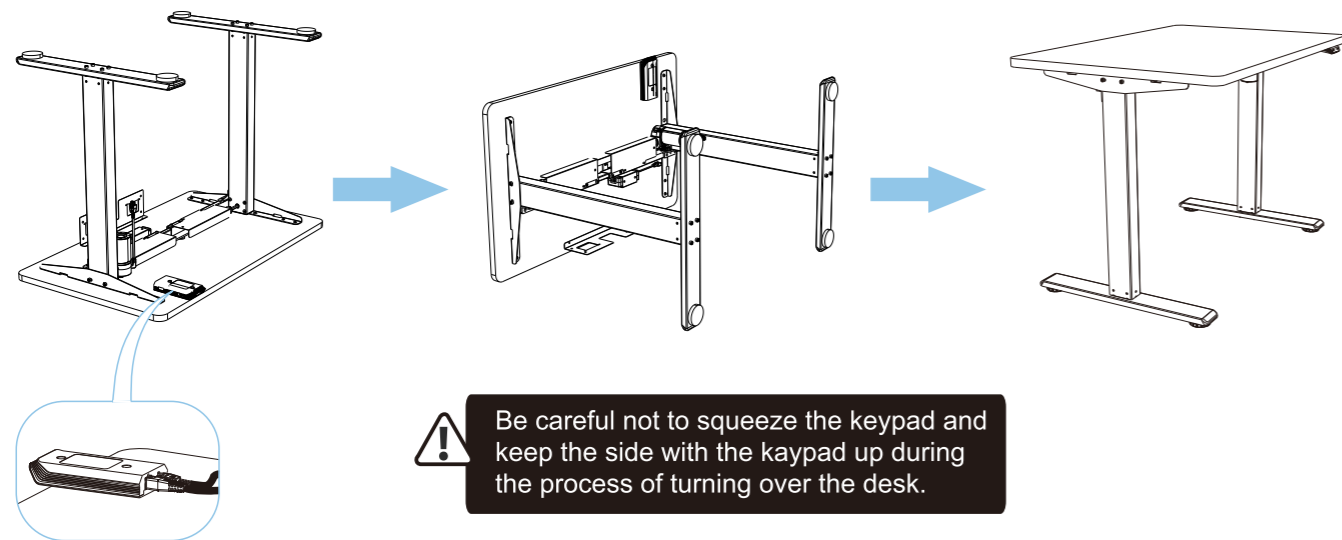

# Keypad Instruction

UP and DOWN buttons

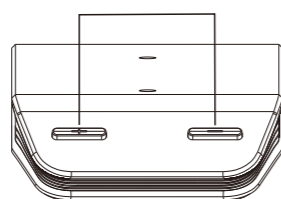

## Fast Charging Features:

**Safety:** Built-in over-temperature protection, over-current protection, short-circuit protection, and output interface current-limiting protection to ensure safe operation of the product;

**Compatibility:** The product is compatible with mainstream smartphones and notebooks on the market and can quickly charge the device.

## Output Parameters:

- Single USB Type-C port output: MAX 45W, 5V=3A, 9V=3A, 12V=3A, 15V=3A, 20V=2.25A;
- Single USB Type-A port output: MAX 27W, 5V=2A, 9V=2A, 12V=1.5A, 15V=1.8A, 20V=0.9A, Compatible with Xiaomi CHARGE TURBO, Huawei FCP/SCP, Samsung AFC protocol.
- When both Type-C and Type-A are connected to the device, the output voltage drops to 5V to power the device, MAX 22.5W.
- Charging function will be paused while adjusting desk height and resume charging once the desk movement stops.

## Reset Function:

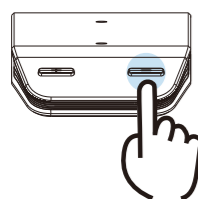

- When the display screen shows "rst", the desk enters the reset state. At this time, press and hold the "-" key until the desk reaches its lowest height and rebounds a little to stop. The display now shows the lowest height, release the "-" key, reset process finished.
- At the lowest position, press and hold the "-" key for 3 seconds; the display will show "rst". Repeat step a to complete the reset.

- Anti-collision function:** The desk will stop automatically when an obstruction is detected while the desk height adjustment is in motion.

- Adjust the Sensitivity of Anti-collision:** Keep pressing "+" and "-" button at the same time for 3 seconds to switch the sensitivity. One operation to switch to one gear, a total of 4 gears (R-1, R-2, R-3);

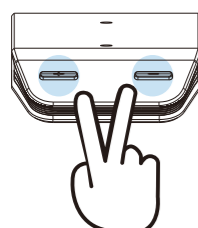

- "R-1", low sensitivity;
  - "R-2", middle sensitivity;
  - "R-3", high sensitivity;
  - "R-4", switch off the anti-collision function.
- ( Before switching off the function please make sure there aren't any object under the desk to prevent potential damage. )

## Troubleshooting:

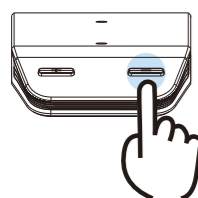

- When the error code E01 or E02 occurs, please retry after more than 18 mins.
- When other error codes occur and the "-" button doesn't work, please confirm the cable is not damaged and is well connected and then cut off the power for more than 10 seconds. Reconnect to the power and LED display shows "rst", then start the reset process by pressing and holding the "-" button.
- If our troubleshooting tips don't yield any success, please contact the customer service.

# Resolving Common Issues



The following tips will help you identify and correct common issues. If you encounter an issue not listed in the table below, or if you follow the instructions below and the issue is still not resolved, please contact your supplier. All such anomalies or errors can only be investigated and corrected by the manufacturer or specially trained personnel.

Problem	Solution
No action when you press "up" or "down" button	Check all cables connected well;
Slow Lifting Speed	Check if the load weighs more than 187 lbs;
The work surface height keeps sliding down	
The desk experiences a lot of automatic resets	
The desk goes down but can't go up, or it goes up but can't go down	Reset;
The desk does not extend fully to the maximum and minimum heights	
The desk cannot be lifted	
Overwork (Duty cycle: max 2min on/18min off)	Suspend it for 18 minutes before connecting power again;



## Recycling and Disposal



This product cannot be disposed of as household waste. To prevent damage to the environment, this product should be recycled. Please use the relevant recycling systems available to you or contract the distributor or manufacturer for recycling assistance.

## Attention



1. Power supply: AC100V-240V, 50/60Hz
2. Service Environment: 32-104°F
3. Unplug the power plug before cleaning, and wipe the dust on the surface with a slightly wet dishcloth when cleaning. Be careful to not let the drops into the internal parts, or into the loose connector.
4. The electric box contains electronic components, metals, plastics, wires, etc. Ensure you dispose of it in accordance with each country's environmental legislation. Do not dispose of them with general household waste.
5. Check carefully to ensure correct and complete assembly before using.
6. Be familiar with all functions and program settings of the product before first use.
7. Children are forbidden to play on the product because of unforeseen hazards. Therefore, the manufacturers will not be liable for any accident caused by this improper action.
8. The slight noise caused by the V-Ribbed belt or brake system within the structure will not have any effect on the use of the equipment.
9. Corrosive or abrasive materials SHOULD NOT be used to clean the equipment. Must ensure that the cleaner used will not pollute the environment.
10. This appliance can be used by children aged 8 years and above. It can also be used by persons with reduced physical, sensory or mental capabilities or lack of experience and knowledge. However, this is on the condition that they're given proper supervision or instructions concerning the use of this appliance in a safe way and understand the hazards involved. Children shall not play with the appliance.
11. Cleaning and user maintenance SHALL NOT be handled by children without supervision.
12. If the supply cord is damaged, it must be replaced by the manufacturer, its service agent, or a similarly qualified person in order to avoid a hazard.
13. Please make sure there are no hazardous sources in your operating environment. e.g., do not litter the tools around. Always be careful to dispose of the packaging materials in order to avoid any possible danger, e.g. plastic bags are a choking hazard to children.
14. Keep the original package of the equipment if necessary in case of future use in transportation.

# FlexiSpot Limited Warranty

This limited warranty offered by FlexiSpot covers defects in material or workmanship in new FlexiSpot products. This warranty extends to the original purchaser only and is non-transferable. Only consumers purchasing FlexiSpot products from authorized FlexiSpot retailers or resellers may benefit from our limited warranty.

## What is Covered?

### FlexiSpot Height Adjustable Desk Frames

All height adjustable desks purchased on or after April 1, 2022 include a limited, non-transferable warranty. We hereby cover all FlexiSpot height adjustable desks for a period of:

**15 years:** all metal and mechanical parts and components, including motors and electrical components of.

FlexiSpot Standing Desk E7  
FlexiSpot Standing Desk E8

**10 years:** all metal and mechanical parts and components, including motors and electrical components of.

FlexiSpot Standing Desk E3  
FlexiSpot Standing Desk E5

**5 years:** all metal and mechanical parts and components, including motors and electrical components of all other height adjustable desk except for E3, E5, E7, and E8.

### Desktop

All Bamboo desktops purchased on or after April 1, 2022, include a 5-year warranty.  
All Chipboard, Fiberboard, Solid wood and Solid wood texture desktops purchased on or after October 5, 2016, include a 2-year warranty.

### FlexiSpot Sit-Stand Desktop Workstations

FlexiSpot Sit-Stand Desk Converters have a 5-year warranty for the frame and desktop. And a 3-year warranty for the gas spring system and other mechanisms.

### Desk Bikes

All desk bikes purchased on or after October 5, 2016, include a 1-year warranty.

### Chairs

All FlexiSpot chairs purchased on or after October 5, 2016, include a 3-year warranty.

### Adjustable bed frame

All FlexiSpot adjustable bed frame purchased on or after November 2, 2021, include a 10-year warranty for the frame, 5-year warranty for the motor, and 2-year warranty for the adapter, remote and control box.

### Monitor Mounts

All monitor mounts purchased on or after October 5, 2016, include a 3-year warranty for the arms, gas spring system, and mechanisms.

## What are your Remedies?

FlexiSpot will replace at no charge to the consumer the defective parts only or, at FlexiSpot's option, replace any product or part of the product that is defective because of improper workmanship and/or material, under normal installation, use, service and maintenance. If FlexiSpot is unable to provide a replacement and repair is not practical or cannot be completed in a timely fashion, FlexiSpot may elect to refund the purchase price in exchange for the return of the product. In the rare event that your FlexiSpot product is defective, we will provide you with a replacement item shipped at no cost to you within the continental United States. The shipping method for replacement products is FedEx Ground, but expedited shipping is available if you choose to pay the additional expense. In addition, you will need to pay the shipping costs if any products need to be shipped to you at an address outside the continental United States.

# FlexiSpot Limited Warranty

**REPAIR OR REPLACEMENT (OR, IN LIMITED CIRCUMSTANCES, REFUND OF THE PURCHASE PRICE) AS PROVIDED UNDER THIS WARRANTY IS THE EXCLUSIVE REMEDY OF THE PURCHASER. FLEXISPOT NEITHER ASSUMES NOR AUTHORIZES ANY PERSON TO CREATE FOR IT ANY OTHER OBLIGATION OR LIABILITY IN CONNECTION WITH THIS PRODUCT.**

## What is Not Covered?

Our limited warranty does not cover any problem that is caused by:

1. Conditions, malfunctions or damage not resulting from defects in material or workmanship.
2. Conditions, malfunctions or damage resulting from normal wear and tear, improper installation, improper maintenance, misuse, abuse, negligence, accident or alteration.
3. Accessories, connected materials and products, or related products not manufactured by FlexiSpot.
4. Conditions, malfunctions or damage resulting from failure to follow the instructions and guidelines relating to the product's intended use.

Our limited warranty is void if a product is returned with removed, damaged or tampered labels or any alterations (including removal of any component or external cover).

## How to File a Claim?

In order to receive the benefit of our limited warranty, you need to process your claim in compliance with the terms of this limited warranty and follow proper return procedure. To request warranty service, please contact customer service via email at [contact@FlexiSpot.com](mailto:contact@FlexiSpot.com) or toll free at +1 (855) 585-5618. You will need to provide the sales receipt or other evidence of the date and place of purchase for your FlexiSpot product.

## Implied Warranties and Limitation of Damages

**EXCEPT TO THE EXTENT PROHIBITED BY APPLICABLE LAW, ALL IMPLIED WARRANTIES (INCLUDING WARRANTIES OF MERCHANTABILITY AND FITNESS FOR A PARTICULAR PURPOSE) SHALL BE LIMITED IN DURATION TO THE DURATION OF THIS WARRANTY, AND FLEXISPOT SHALL NOT BE LIABLE FOR ANY INCIDENTAL, INDIRECT, SPECIAL, OR CONSEQUENTIAL DAMAGES, INCLUDING BUT NOT LIMITED TO LOSS OF PROFITS OR REVENUE, RESULTING FROM ANY BREACH OF EXPRESS OR IMPLIED WARRANTY OR CONDITION, OR UNDER ANY OTHER LEGAL THEORY, EVEN IF FLEXISPOT HAS BEEN ADVISED OF THE POSSIBILITY OF SUCH DAMAGES.** Some jurisdictions do not allow limitations on the duration of an implied warranty or the exclusion or limitation of special, indirect, incidental or consequential damages, so the above limitations or exclusions may not apply to you.

## Governing Law

This Warranty shall be governed by the laws of the State of California, USA, without giving effect to any conflict of laws principles that may provide the application of the law of another jurisdiction.

## How State Law Applies

This Warranty gives you specific legal rights, and you may also have other rights which vary from state to state.