

**Work  
like new**

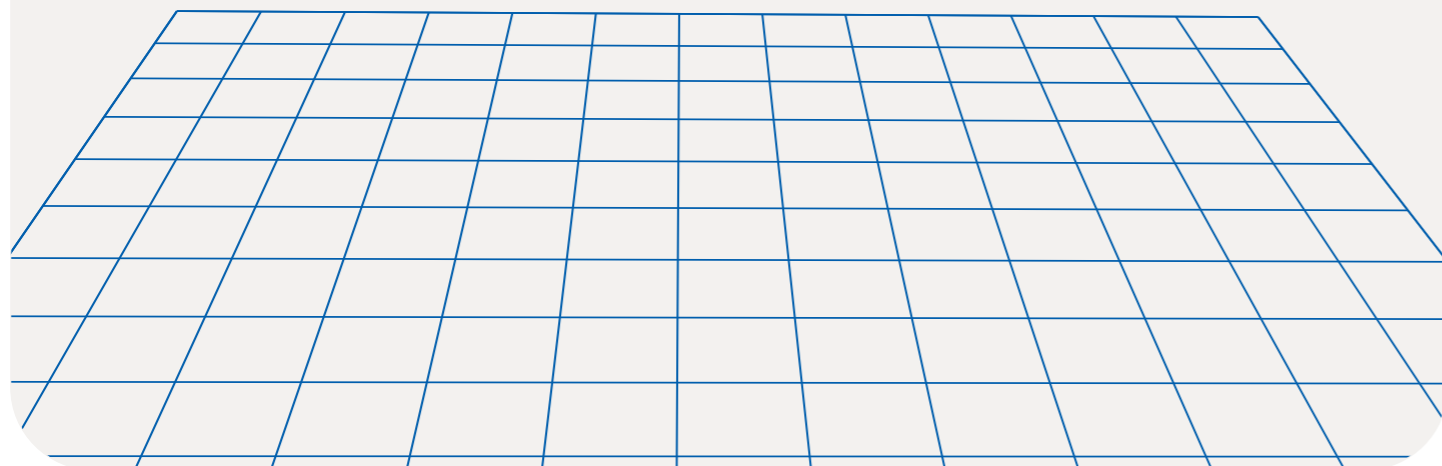

# FlexiSpot

Item No. E5B-A/E5W-A/E5S-A  
User Manual

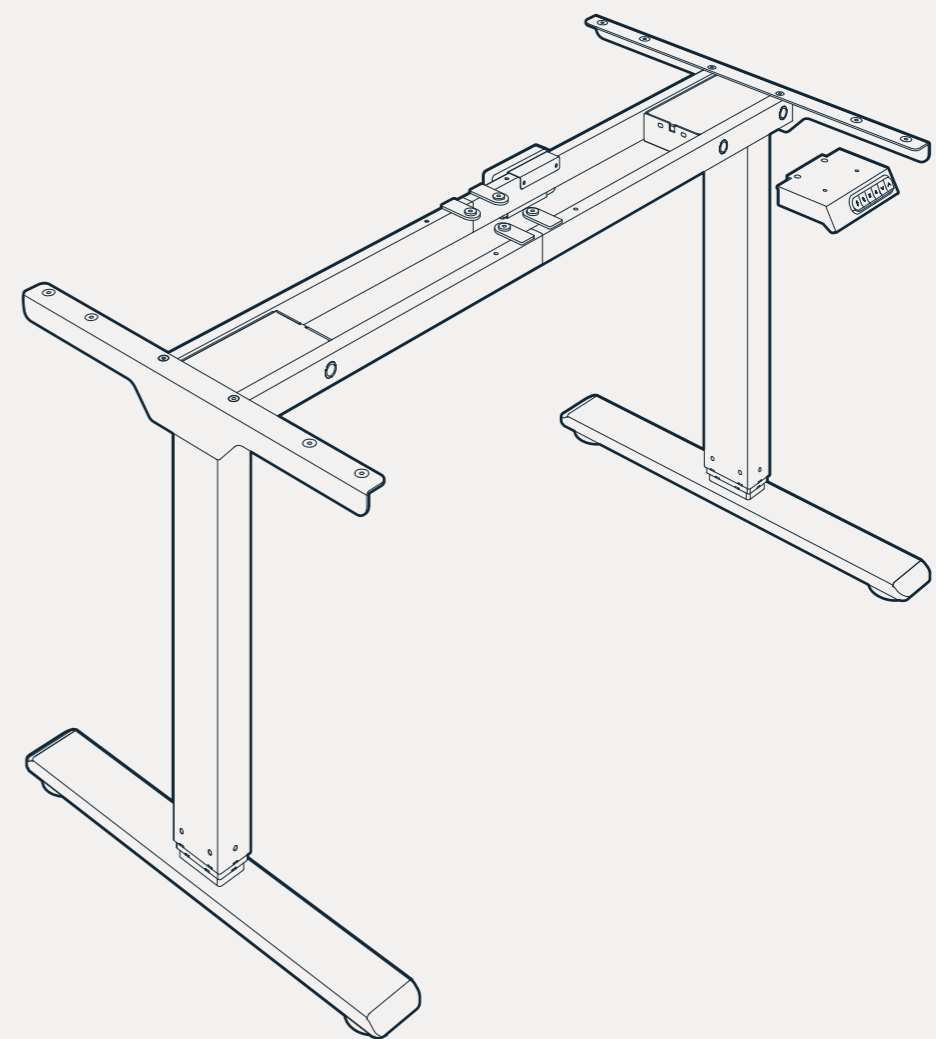

# CONTENTS

Specifications-----	1
Assembly Notes-----	1
Product List-----	1
Parts Included-----	2
Assembly Steps-----	3
Keypad User Guide-----	6
Resolving Common Issues-----	7
Attention-----	8
Limited Warranty-----	9

## Specifications

Lifting Column Design	3 stage
Max. Weight Capacity	220 lbs (100 kg)
Desktop Size	47.2"-70.8" (1200-1800mm)
Height Range (Min to Max)	23.6"-49.2" (600-1250mm) without desktop
Input Voltage	100-240V
Duty Cycle	10%(Working 2 minutes then stop 18 minutes)
Working Temperature	32°F-104°F

## Assembly Notes

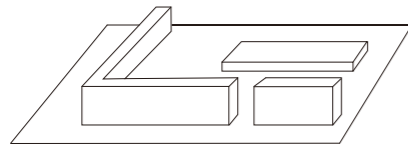

Assemble on carpet to prevent scratches

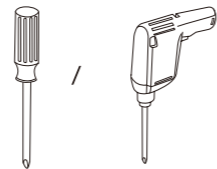

Phillips screwdriver or drill required (not provided)

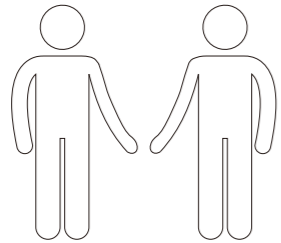

Cooperative assembly

## Product List

### Accessory Package

Note: The following line drawings are for reference only and in some cases may be different from the actual part; please refer to the actual part. If you find missing parts or have installation problems, please contact customer service.



Ax8

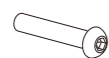

Bx8



Cx12



Dx6



Ex6



Fx1



Gx4

## Parts Included

No.	Part	No.	Part
①	Feet x 2	⑥	Side Bracket x 2
②	Lifting column x 2	⑦	Handset x 1
③	Connection rod x 2	⑧	Screw for Handset x 1
④	Support beam (left) x 2	⑨	Adapter x 1
⑤	Support beam (right) x 2	⑩	Extension Cord x 1

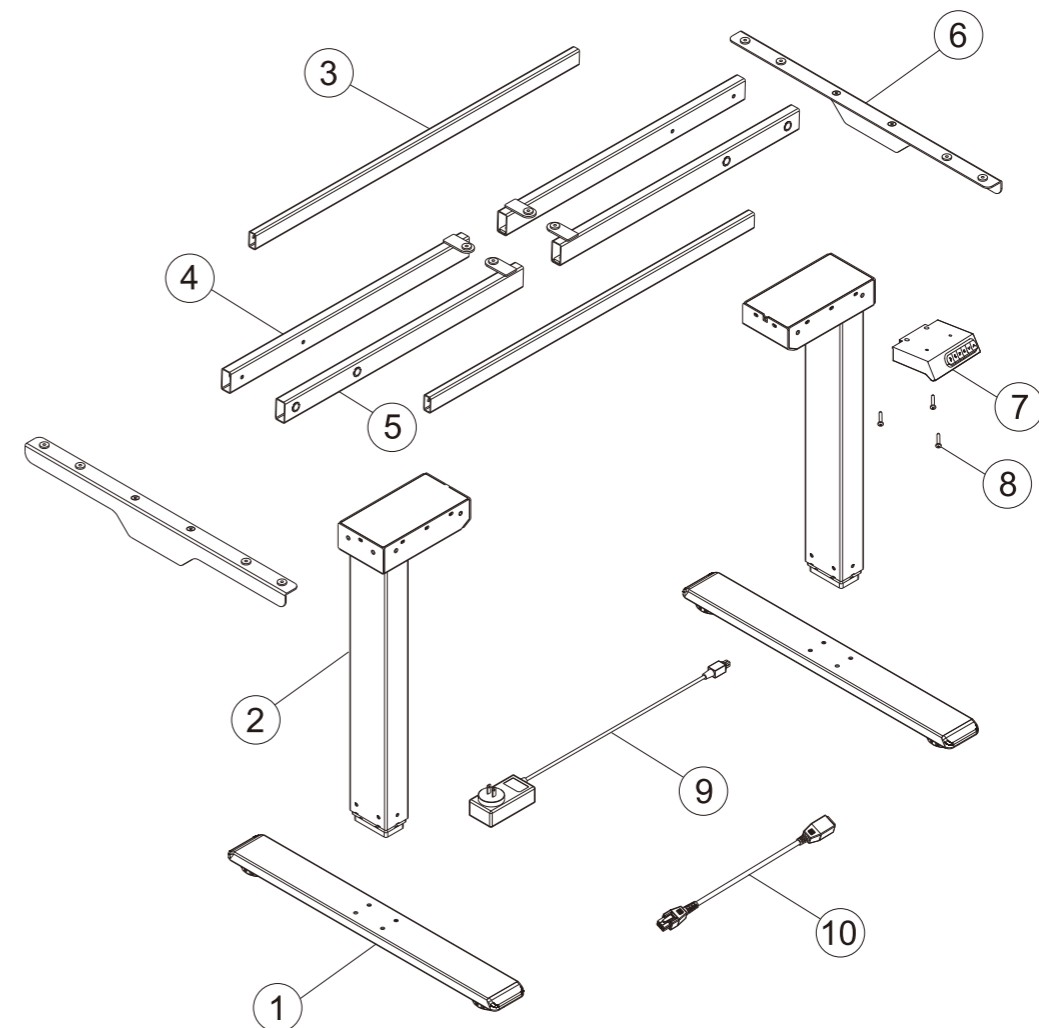

## 1 Install supporting beam

Using screws (A) to connect the left and right supporting beams (4) & (5) to the lifting column (2), and tighten them with 4\*4 allen key (F).

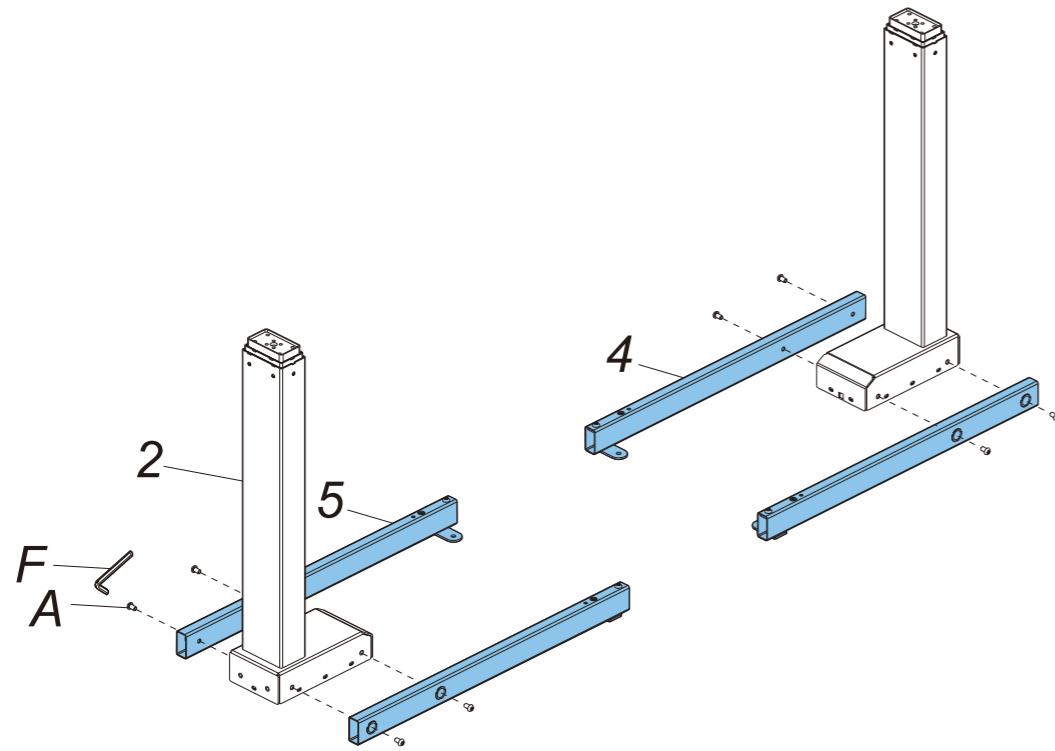

## 3 Install connection rod

1. Use 4x4 allen key (F) to loosen screws in the left and right supporting beams (4) & (5).
2. Insert the connection rod (3) into left and right supporting beam (4) & (5).

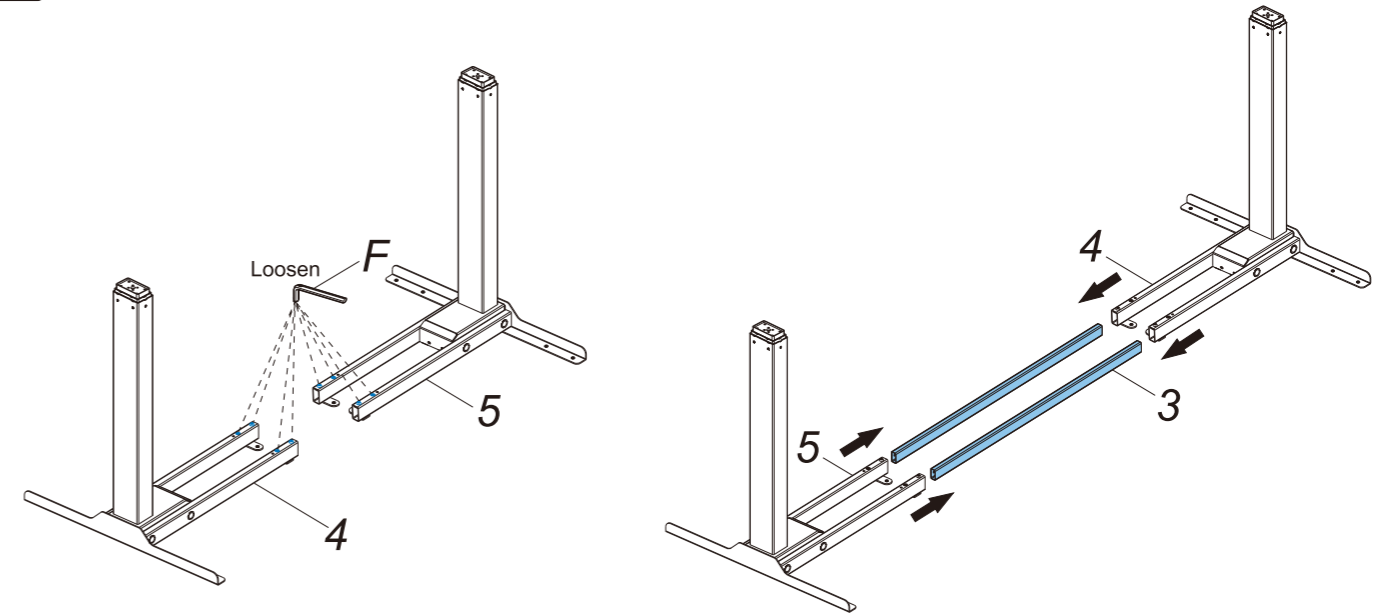

## 2 Install side bracket

Connect side bracket (6) to the lifting column (2) with screw (G) and use 4\*4 allen key (F) to tighten.

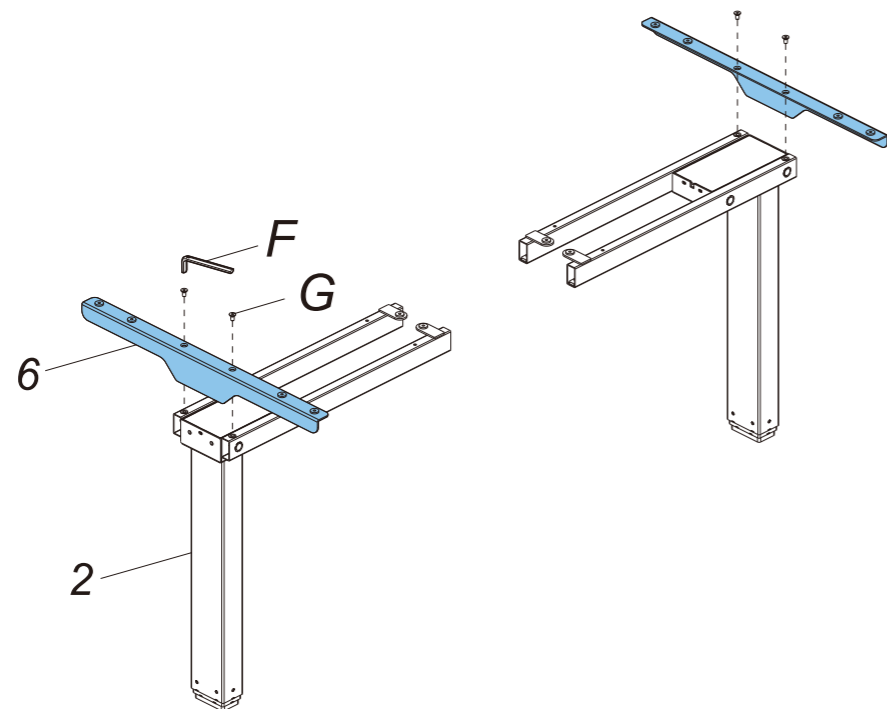

## 4 Install feet

Use screw (B) to connect feet (1) & (2) and tighten it with 4x4 allen key (F).

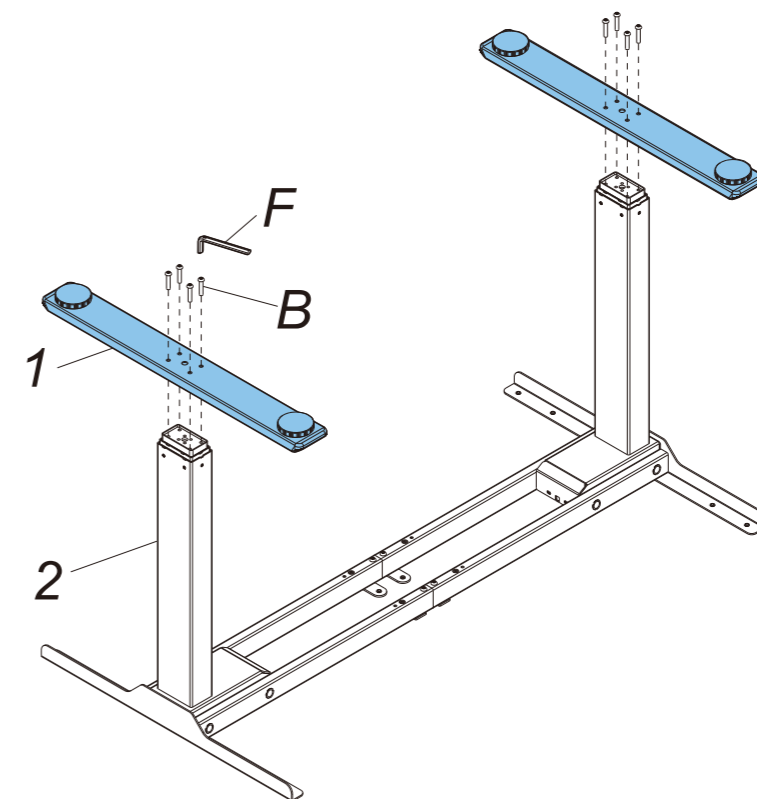

## 5 Install tabletop and handset

Fix the tabletop with screw ©. Then use screw (8) to fix the handset (7) on the tabletop and use hand drill to tighten.

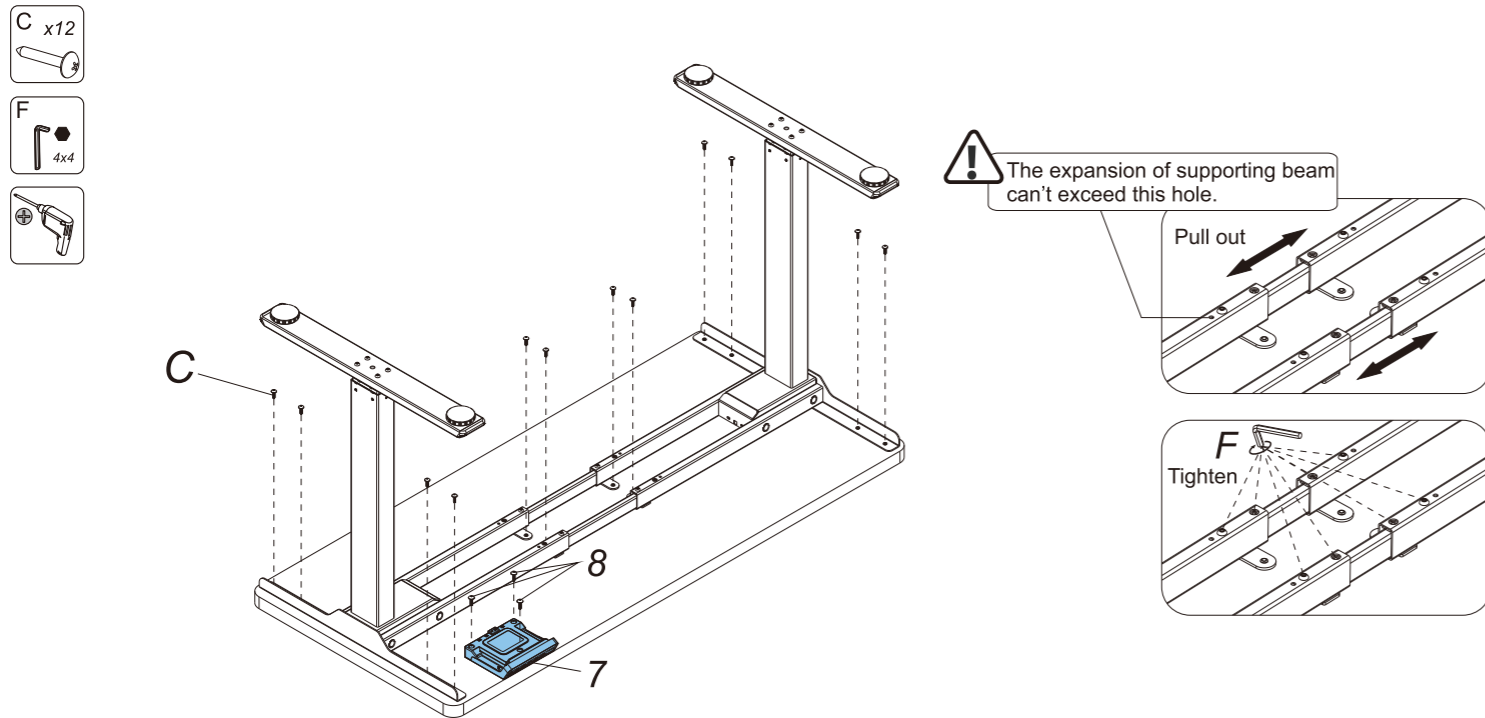

## 6 Connect cables to the handset

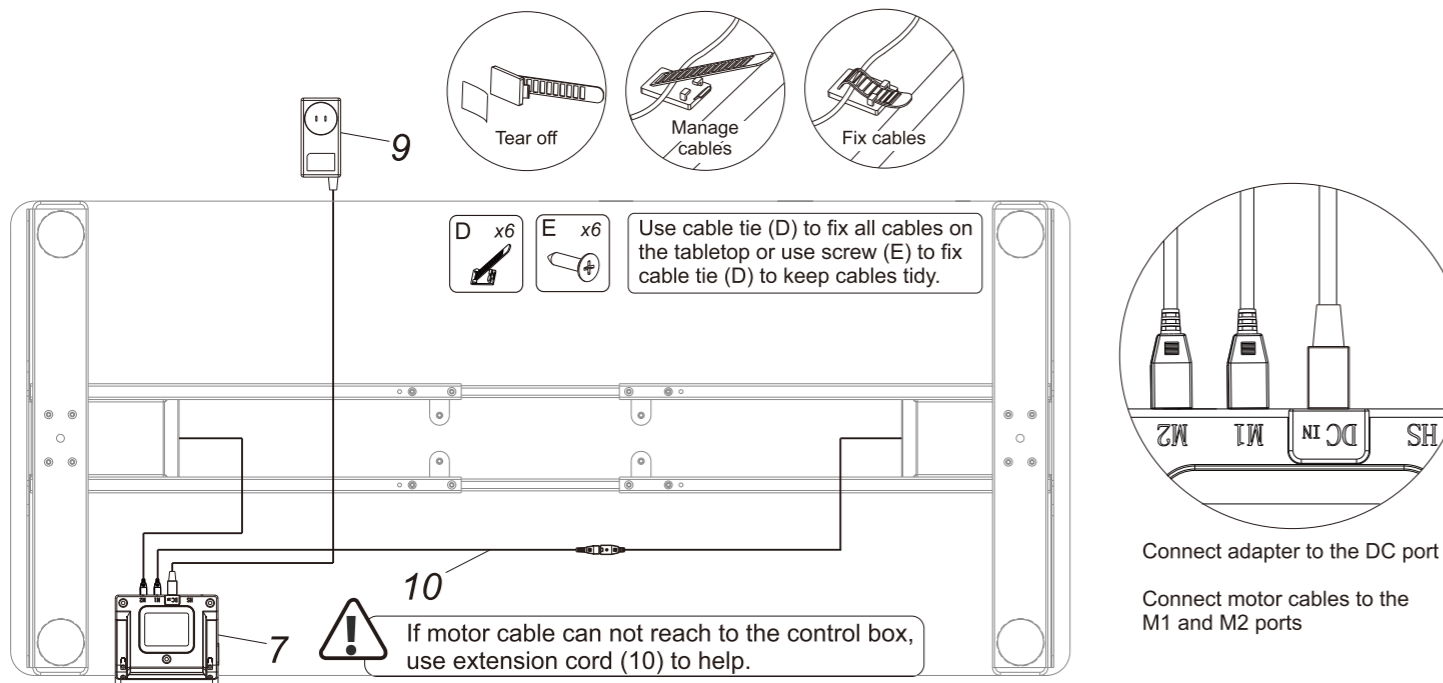

## Keypad User Guide

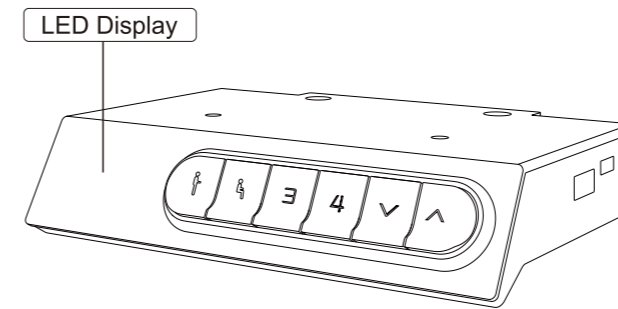

Button introduction: There are 6 buttons that "▲", "▼", "1", "2", "3", "4"

- (1) "▲": Adjust the desk upwards
- (2) "▼": Adjust the desk downwards
- (3) "1": Position 1, the first height user save
- (4) "2": Position 2, the second height user save
- (5) "3": Position 3, the third height user save
- (6) "4": Position 4, the fourth height user save

### Operating Instructions

- **Lifting Function:**  
The height of the desk can be adjusted up or down by pressing the "▲" or "▼" button, and the current height will show on the display.
- **Height Memory Function:**
  1. When the desk is in a static state, long press the button "1" for three seconds, the display shows "5-1", which means the save is successful.
  2. Buttons "2", "3", and "4" all have the same height memory function as button "1", repeat the above steps to save the height to the corresponding position 2 or 3 or 4, and the display screen will correspondingly show "5-2" or "5-3" or "5-4".
  3. When the tabletop is at any height, press the "1" or "2" or "3" or "4" button to automatically adjust to the previous saved location.
- **29V DC power supply function**
  1. In the operating state of the desk, the 2pin at the back of the control box does not output a DC 29V voltage.
  2. In the static state of the desk, the 2pin at the back of the control box will output a DC 29V voltage.
- **Anti-Collision Sensor Level Adjustment**
  1. Simultaneously press and hold the "▲" and "▼" buttons for 5 seconds to switch the sensitivity. One operation can switch to one level, divided into 4 levels—"A-0", "A-1", "A-2", "A-3".
  2. The display shows "A-0" means the anti-collision function is turned off; the display shows "A-1" means low sensitivity; the display shows "A-2" means medium sensitivity; the display shows "A-3" means high sensitivity.
  3. When the desk rises or falls, it will rebound immediately when encountering obstacles to prevent damage.
- **Code Processing**
  1. Reset function definition: When the LED display shows "A5f" or "r5t", keep pressing the "▼" button until the desk reaches the lowest position and bounces up to stop, the display shows the lowest height, release the "▼" button to reset, then the desk can be used normally.
  2. If the words "E01" or "E02" appear, please let the desk rest for more than 18 minutes before it can be used normally.
  3. If other codes appear and there is no response after pressing the "▼" button, please make sure that the cable is not damaged and the connection is normal, and power off for more than 10 seconds, then turn on the power again, "A5f" or "r5t" is displayed, then long press the "▼" button to reset.
  4. If the above operations are performed, the table still does not operate normally, please contact customer service.

## Resolving Common Issues

This list is used for checking and solving common faults and errors. Please contact the manufacturer if problem you encounter is not on the list below.

Fault phenomenon	Method
The desktop could not function	Check if all the cables well connected;
Rising in a low speed	Check if overloaded, max loading: 220 lbs;
The desk moving downwards without any operation	
Automatically Self-Reset	
Go down but not go up or go up but not go down	Reset;
The upper and downward height is not enough	
The desk could not lifted	
Overwork (Duty cycle: Max 2min on/18min OFF)	Restart after suspend for 18mins while connecting with power.

## Attention

- Power supply: AC100 - 240 V, frequency 50/60HZ;
- Working environment: 32°F - 104°F;
- Before cleaning, you have to unplug the power supply cable. Clean with a slightly damp cloth to wipe away the surface dust. Keep all electrical components away from liquids. Do not damage the connection line and keep the plug in a safe position.
- Inside the control box, there are electronic components, metal parts, plastic parts, wires and so on. They should be disposed in accordance with the local laws and regulations. They cannot be disposed as household waste.
- Before using the product, please make sure the product has been installed correctly.
- Before starting use of the product, please read the instructions to fully understand all the product's functions and settings.
- Keep children away from electric height-adjustable desks, control units and handsets. Manufacturer is not responsible of any damages that result from children's unpredictable behaviour.
- Slight noise caused by the multi wedge belt or brake system will not impact the use of this product.
- Do not use corrosive or abrasive materials to clean this product and please dispose of cleaning solutions in an environmentally friendly manner.
- Understand the risks associated with using this product. Children or those with cognitive impairment should not use this product without supervision.
- If the power supply cord is damaged or broken, it must be replaced by the manufacturer or a relevant specialist to avoid any injuries.
- Please operate in a clean and safe environment. For example, do not left around your tools. And always be careful to deal with packaging materials, in order to avoid any kinds of possible danger. Potential choking risk exists when children play with plastic bags!
- If necessary, retain the original package for future transportation.

## Recycling and Disposal

This product cannot be disposed of as household waste. To prevent damage to the environment, this product should be recycled. Please use the relevant recycling systems available to you or contract the distributor or manufacturer for recycling assistance.

# FlexiSpot Limited Warranty

This limited warranty offered by FlexiSpot covers defects in material or workmanship in new FlexiSpot products. This warranty extends to the original purchaser only and is non-transferable. Only consumers purchasing FlexiSpot products from authorized FlexiSpot retailers or resellers may benefit from our limited warranty.

## What is Covered?

The FlexiSpot limited warranty covers our products against defects in material or workmanship as follows:

### ·FlexiSpot Height Adjustable Desk Frames

15 years: all metal and mechanical parts and components, including motors and electrical components of FlexiSpot Standing Desk E7 series.

10 years: all metal and mechanical parts and components, including motors and electrical components of FlexiSpot Standing Desk E5 series.

5 years: all metal and mechanical parts and components, including motors and electrical components of all other height adjustable desk except for E5, E7 series.

### ·FlexiSpot Sit-Stand Desktop Workstations

All standing desks purchased on or after October 5, 2016 include a 5-year warranty for the frame, medium-fiber desktop and mechanisms.

### ·FlexiSpot Desk Bikes

All desk bikes purchased on or after October 5, 2016 include a 3-year warranty for the frame, and a 1-year warranty for the electronics and other mechanisms.

### ·FlexiSpot Mini Steppers

All desk bikes purchased on or after October 5, 2016 include a 1-year warranty for the frame, and other mechanisms.

### ·Accessories

All monitor mounts purchased on or after October 5, 2016 include a 5-year warranty for the arms, 3-year warranty for gas spring system and mechanisms.

## What are your Remedies?

FlexiSpot will replace at no charge to the consumer the defective parts only or, at FlexiSpot's option, replace any product or part of the product that is defective because of improper workmanship and/or material, under normal installation, use, service and maintenance. If FlexiSpot is unable to provide a replacement and repair is not practical or cannot be completed in a timely fashion, FlexiSpot may elect to refund the purchase price in exchange for the return of the product. In the rare event that your FlexiSpot product is defective, we will provide you with a replacement item shipped at no cost to you within the continental United States. The shipping method for replacement products is FedEx Ground, but expedited shipping is available if you choose to pay the additional expense. In addition, you will need to pay the shipping costs if any products need to be shipped to you at an address outside the continental United States.

**REPAIR OR REPLACEMENT (OR, IN LIMITED CIRCUMSTANCES, REFUND OF THE PURCHASE PRICE) AS PROVIDED UNDER THIS WARRANTY IS THE EXCLUSIVE REMEDY OF THE PURCHASER. FLEXISPOT NEITHER ASSUMES NOR AUTHORIZES ANY PERSON TO CREATE FOR IT ANY OTHER OBLIGATION OR LIABILITY IN CONNECTION WITH THIS PRODUCT.**

# FlexiSpot Limited Warranty

## What is Not Covered?

Our limited warranty does not cover any problem that is caused by:

1. Conditions, malfunctions or damage not resulting from defects in material or workmanship.
2. Conditions, malfunctions or damage resulting from normal wear and tear, improper installation, improper maintenance, misuse, abuse, negligence, accident or alteration.
3. Accessories, connected materials and products, or related products not manufactured by FlexiSpot.
4. Conditions, malfunctions or damage resulting from failure to follow the instructions and guidelines relating to the product's intended use.

Our limited warranty is void if a product is returned with removed, damaged or tampered labels or any alterations (including removal of any component or external cover).

## How to File a Claim?

In order to receive the benefit of our limited warranty, you need to process your claim in compliance with the terms of this limited warranty and follow proper return procedure. To request warranty service, please contact customer service via email at [contact@FlexiSpot.com](mailto:contact@FlexiSpot.com) or toll free at 1-855-585-5618. You will need to provide the sales receipt or other evidence of the date and place of purchase for your FlexiSpot product.

## Implied Warranties and Limitation of Damages

**EXCEPT TO THE EXTENT PROHIBITED BY APPLICABLE LAW, ALL IMPLIED WARRANTIES (INCLUDING WARRANTIES OF MERCHANTABILITY AND FITNESS FOR A PARTICULAR PURPOSE) SHALL BE LIMITED IN DURATION TO THE DURATION OF THIS WARRANTY, AND FLEXISPOT SHALL NOT BE LIABLE FOR ANY INCIDENTAL, INDIRECT, SPECIAL, OR CONSEQUENTIAL DAMAGES, INCLUDING BUT NOT LIMITED TO LOSS OF PROFITS OR REVENUE, RESULTING FROM ANY BREACH OF EXPRESS OR IMPLIED WARRANTY OR CONDITION, OR UNDER ANY OTHER LEGAL THEORY, EVEN IF FLEXISPOT HAS BEEN ADVISED OF THE POSSIBILITY OF SUCH DAMAGES.** Some jurisdictions do not allow limitations on the duration of an implied warranty or the exclusion or limitation of special, indirect, incidental or consequential damages, so the above limitations or exclusions may not apply to you.

## Governing Law

This Warranty shall be governed by the laws of the State of California, USA, without giving effect to any conflict of laws principles that may provide the application of the law of another jurisdiction.

## How State Law Applies

This Warranty gives you specific legal rights, and you may also have other rights which vary from state to state.