

FlexiSpot

Massage Chair

OM300/OM301

OPERATION INSTRUCTIONS

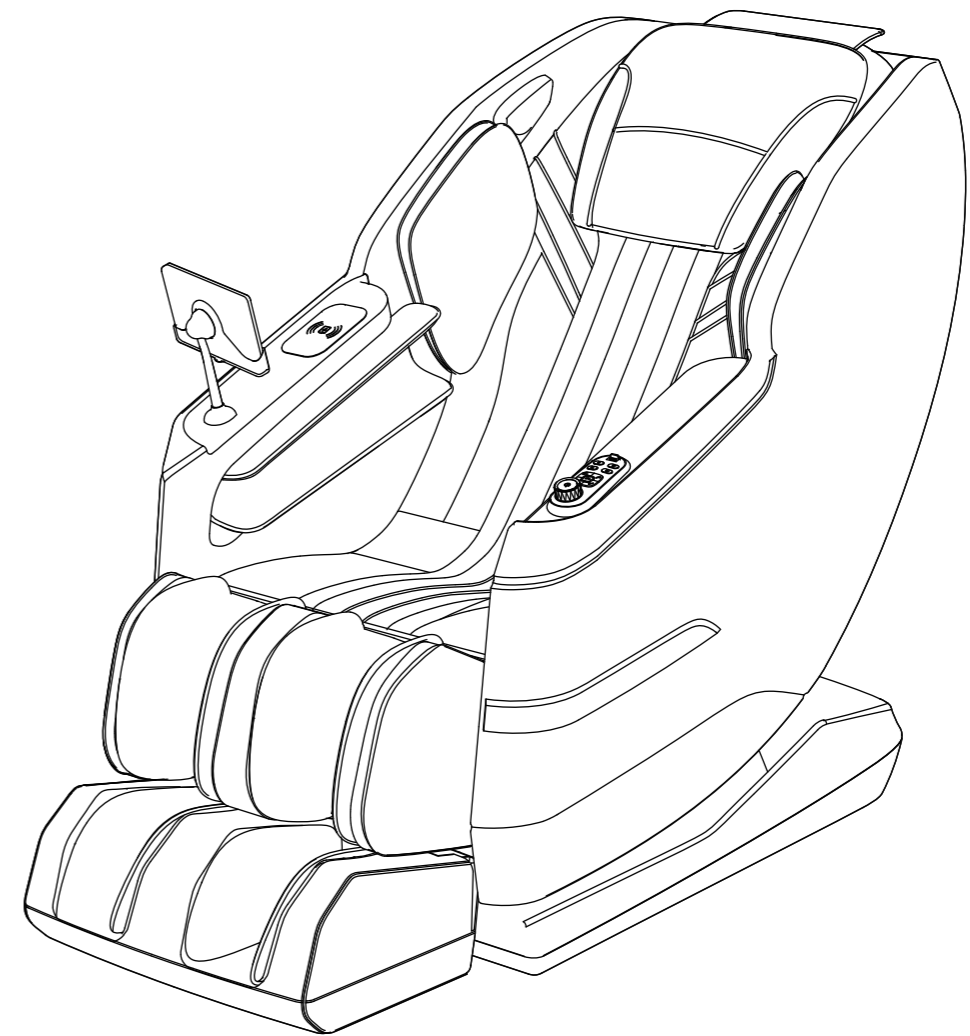

SAVE THESE INSTRUCTIONS

Website: www.flexispot.com

Tel: 1-855-585-5618

Address: 6475 Las Positas Rd. Livermore, CA 94551

Before operating this unit, please read these instructions completely.

Thanks for purchasing this product. Please read this manual instruction carefully in order to know how to use this product correctly before operation. Please pay more attention to some important safety warning and keep this manual book properly for future use.

CONTENTS

Before Use

Safety Precautions-----	01-03
Before Use-----	04-05
Product Structure-----	06-11

Usage Method

Operation Instructions-----	12-13
-----------------------------	-------

Maintain

Care and Maintenance-----	14-15
---------------------------	-------

Important

Troubleshooting Guide-----	16-17
Product Specifications-----	17-18

Safety Precautions

must be observed

The following safety instructions will greatly help ensure the correct use of this massage chair.

- **READ ALL THE INSTRUCTIONS** and cautionary markings in this manual. Follow the instructions and keep the owners manual for future reference.
- **NOT FOR CHILDREN.** This device can only be used by individuals over 16 years old, and by people with reduced physical, sensory, or mental capabilities, or those lacking experience and knowledge, if they have been given supervision or instruction concerning the safe use of the appliance and understand the hazards involved. Do not allow the device to be used as a toy. Close supervision is necessary when used by or near children. Children should be supervised to ensure they do not play with the device or cords.
- **USE ONLY AS INSTRUCTED.** Use this device only as described in this manual. Any misuse excludes liability for damage; incorrect use may cause electric shocks, fires, burns, or other unexpected hazards. To clearly indicate the degrees of danger and damage, accidents caused by incorrect use are classified into DANGER, FORBIDDEN, WARNING, and CAUTION. Instructions marked as follows must be strictly adhered to.

To reduce the risk of electric shock



DANGER

- A massage chair should never be left unattended when plugged in. Unplug it from the mains socket immediately after use and before cleaning.
- To avoid fire hazards or damage to the massage chair, do not use a power supply that exceeds the specified voltage.
- Close supervision is necessary when this massage chair is used by, on, or near children, invalids, or disabled individuals. Keep children and pets away from the reclining backrest and leg rest.

The following populations should not use this product



WARNINGS

- Do not allow children or pets to play near the chair, especially during operation.
- Do not leave mobility-impaired or speech-impaired individuals alone in the chair.
- Do not place or store this machine near damp places such as swimming pools or bathrooms.
- Do not use it in environments that are dusty, greasy, or lacking oxygen.
- Do not place it directly under the sun.
- Do not use it outdoors.
- Do not apply excessive force to the massage rollers.
- Do not stand on or in the chair, and never store heavy items on the chair. Use it only while seated.
- Do not sit on the backrest, leg rest, or armrest to avoid accidental injury or machine damage.
- Do not use an electric blanket while using the massage chair.
- Do not operate with more than one user.
- Do not use the chair when your body is wet or moist, or on bare skin; wear suitable clothing.
- Do not use the chair while smoking.
- Do not use it immediately after meals or after consuming alcohol.
- Do not wear head ornaments during use.
- Avoid tripping over electrical wires or connections.

Safety Precautions

must be observed

To reduce the risk of burns, fire, electric shock, or injury



WARNINGS

- Do not operate any equipment with damaged parts.
- Do not use attachments not recommended by the manufacturer. Any other use not recommended by the manufacturer may cause electrical shock or injury.
- Before using, uncover the back cushion to check for any damage to the backrest or fabric. If damaged, stop using the massage chair immediately and contact Mynta Customer Support Team.
- Never operate this massage chair if it has a damaged cord or plug, if it is not working properly, or if it has been dropped or damaged. Contact Mynta Customer Support Team.
- Operate the massage chair only on flat ground.
- Connect this appliance to a properly grounded outlet only. See Grounding Instructions.
- To disconnect, turn all controls to the off position, then remove the plug from the outlet.
- Keep the cord away from heated surfaces and heavy traffic areas.
- Do not carry the massage chair by the power cord or use the cord as a handle.
- Do not unplug the power cord or operate the controller with damp hands, and do not place heavy objects on the controller or tablet.
- When removing the power plug, hold the insulated part; do not pull the cord.
- Do not place your hands or head under the chair.
- Only users under 265 lbs (120 kg) are allowed.
- Empty your pockets and remove any jewelry or watches before use.
- Do not operate the chair under a blanket or pillow. Excessive heat may cause fire, electric shock, or injury.
- Do not operate the massage chair with blocked air openings. Keep the air openings free from lint, hair, or similar obstructions.
- Do not drop or insert objects into any openings.
- Do not use the chair where aerosol (spray) products are being used.
- Do not remove the back cushion and play with the roller mechanism, or remove the seat cushion and play with the actuators.
- Do not touch or rewire the wires connected to the control box.
- Do not attempt to repair or adjust any electrical or mechanical functions of this unit. Doing so will void the warranty.
- When using the massage chair, ensure the leg rest is in the lowest position.
- When adjusting the leg rest or backrest, do not apply excessive force, and ensure children and pets are kept away.
- Do not use other therapeutic equipment simultaneously with this massage chair.
- Do not use the chair on areas with insensitive skin or in the presence of poor circulation.
- The unattended use of heat by children or incapacitated individuals may be dangerous.
- The massage chair is equipped with a heating function, so individuals who are insensitive to heat must use it carefully to avoid burns.
- Do not continuously use the massage chair for more than 30 minutes, and limit massages on any specific body part to 5 minutes.
- Do not sleep in the massage chair while it is operating.
- **If you feel uncomfortable during use, stop using the chair immediately and consult your doctor.**

Safety Precautions

must be observed





CAUTION

- The massage chair is designed as a non-clinical device to soothe tired and aching muscles. It is not intended to be a substitute for medical attention.
- Each massage—even a hand massage—should be avoided during pregnancy or if one or more of the following conditions are present in the massage area:
 - Blood stasis
 - Tumor site
 - Heart disease, or if you have a pacemaker or defibrillator
 - Sensitive areas: head, face, cervical vertebrae, spine, vertebral body
 - Areas close to bones with minimal muscle coverage, such as the humerus, the back of the foot, or the back of the hand
- The massage chair is not recommended for the following people:
 - Patients with serious hyperostosis
 - Patients with swollen lumps or thrombosis
 - Patients with serious heart conditions
 - Pregnant women
 - People who consume large amounts of alcohol
 - People with diabetes
 - People suffering from high fever
 - People with distorted joints
 - People with serious skin conditions
 - People with spinal injuries
 - Minors under 16 years of age or individuals unable to control their behavior, such as mental patients or those with paralysis, should not be allowed to operate the massage chair.
- It is recommended to consult a doctor before using the massage chair for the treatment of ailments or illnesses.
- If you rely on electrical aids such as pacemakers, you **MUST** consult your doctor for medical advice before using the massage chair.
- If your symptoms persist or worsen after use, contact your doctor immediately.
- Do not use the chair after taking painkillers, sedatives, or alcohol. Consult your doctor if you are taking medications.

Before Use

must be observed

Environment Check

- Do not use the chair in wet places such as near a swimming pool or bathroom to avoid electric leakage or shock.
- Do not use the chair under direct sunlight, near a stove, or other heating devices to avoid fire or damage to the leather material.
- Please use the chair on a flat surface to avoid it falling, making noise, or causing other unexpected issues.
- Make sure there are no children, pets, or any other objects under or close to the product while in use.

Before Use

must be observed

Moving the Chair

There are rollers at the bottom of the chair for easy movement.

Press down on the backrest as shown below, recline the chair to approximately 45°, and hold the moving handles in the back and front to move the chair around with a slight push or pull.

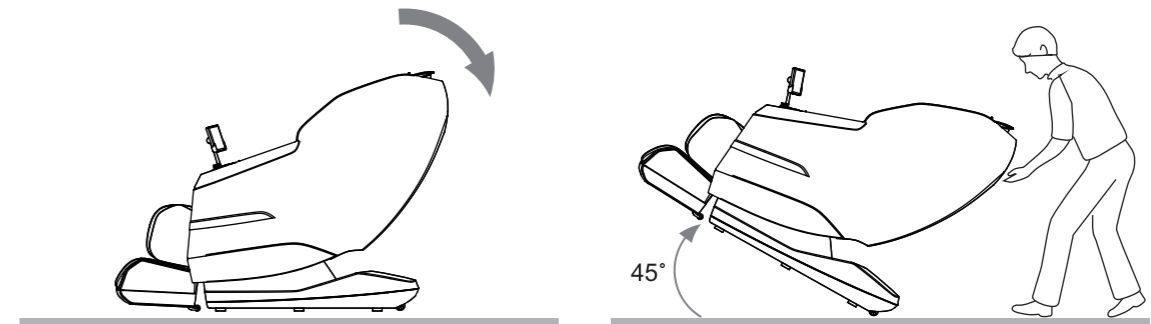

Always hold the side panels, not the base, when lifting the chair.

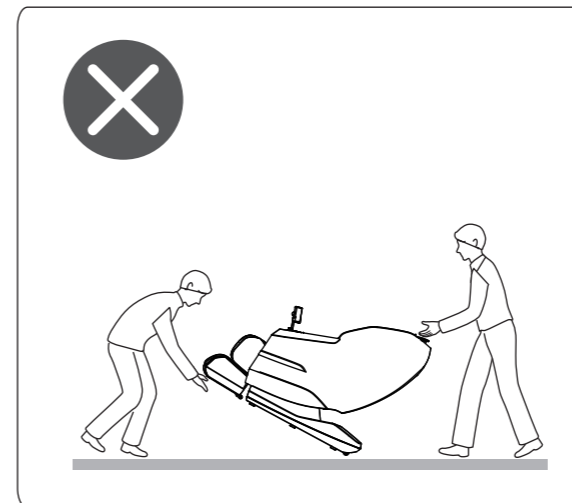



CAUTION

- Do not move the chair when there are people seated in it.
- Do not pull the armrests or any airbags to move the chair.
- Do not put fingers or any objects into the gap between the seat and legrest.
- When adjusting the up and down angles of the backrest and legrest, make sure there are no obstacles around the massage chair.
- During use, ensure the power cord is not stretched or clamped but neatly arranged.
- Before sitting in the chair, make sure it is in its original position. If any part is not in its initial position, please power it on/off again to reset the chair.
- If the legrest is raised, don't attempt to sit in the chair.
- Do not apply sudden heavy pressure on the legrest, as this may damage the legrest mechanism.

Before Use must be observed

Massage Chair Commissioning

Before commissioning, please make sure there is enough space around the chair.

Back: Minimum of 8 inches from the wall or any other obstacles
 Front: Allow 6 inches from any obstacles for the legrest to extend.

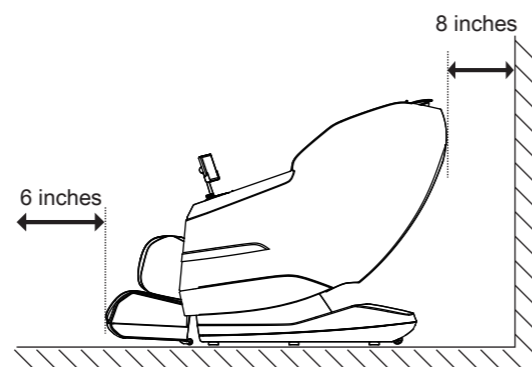

Check around

Make sure that there are no people, pets and other objects around the unit.

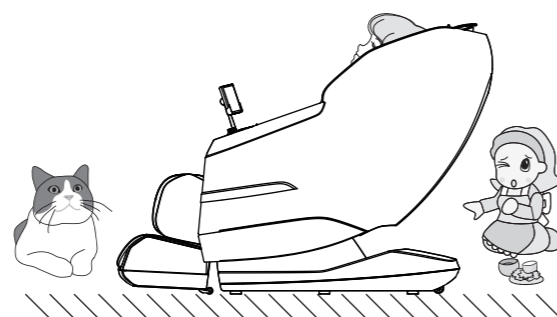

Floor protection

Place a carpet or pad under the massage chair to avoid any potential damage to the floor.

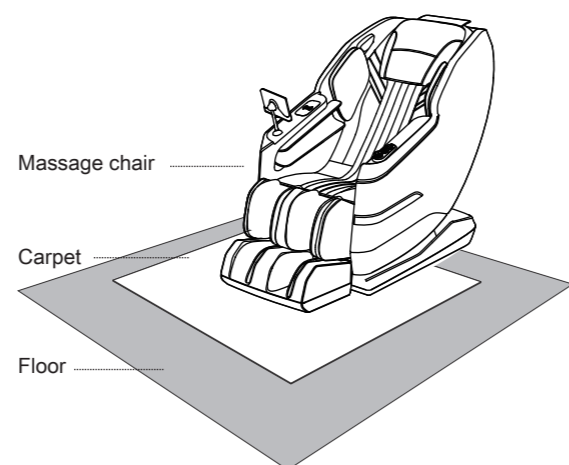

Product Structure must be observed

Warning: Only rated supply 110V must be used to avoid damage to electronic elements.

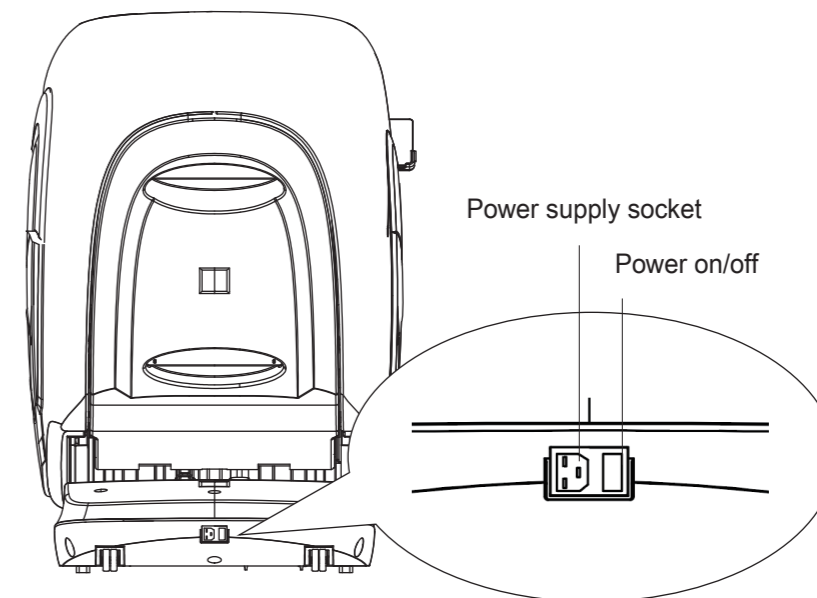
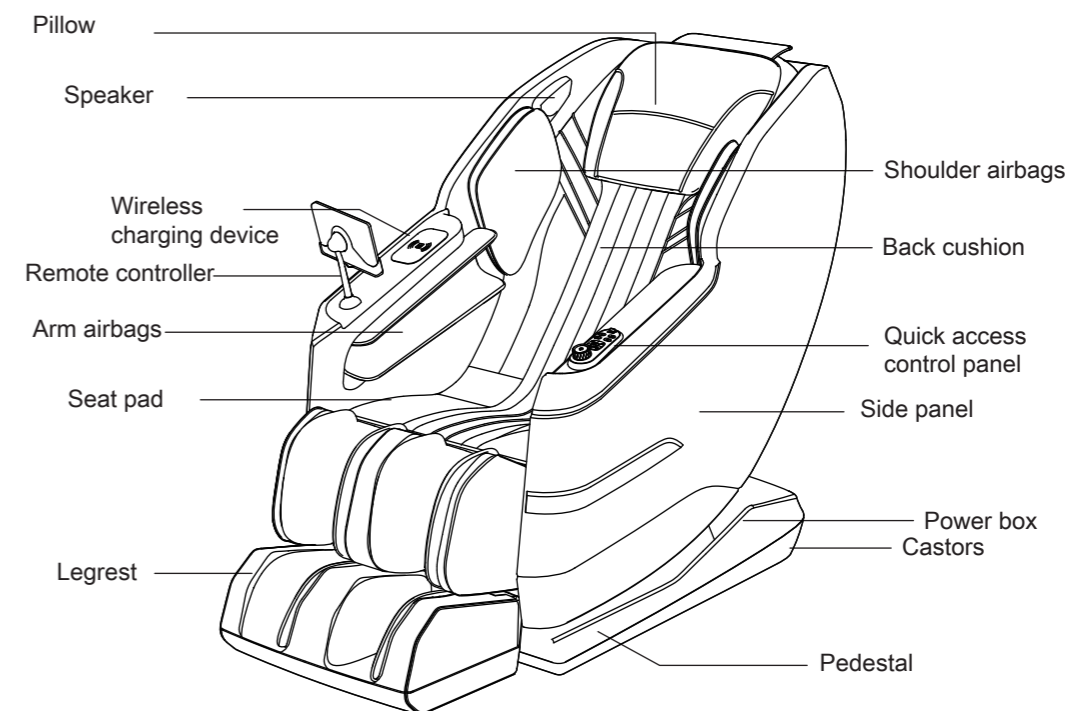

- Do not allow children to play on the chair to prevent accidents.
- Always power off the chair and unplug it from the power supply after use and when not in use to prevent children from accidentally starting the chair.

Product Structure must be observed

Controller

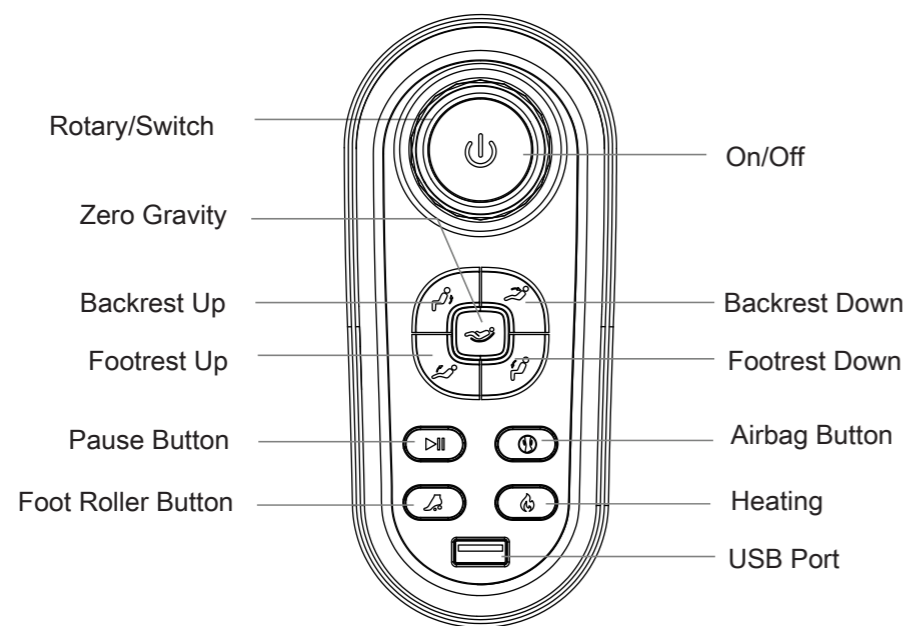

Function	Description
On/Off	1.Press the button to reset massage chair. 2.Long-press this button to enter to the startup state,enter body scanning. In the power-on state,long-press this button again to turn off the massage chair. After the chair is restored to original position,the machine can be restarted again.
Rotary/Switch	Rotate this switch clockwise,and the automatic program runs in sequence. Rotate this switch counterclockwise and the automatic program runs in reverse order.
Backrest Up	Press and hold to raise the backrest to upright position,release the button to stop.
Backrest Down	Press and hold to recline the backrest, release the button to stop.
Zero Gravity	Adjust the gears of zero gravity:first gear-second gear-third gear,cycle in sequence.
Footrest Up	Press and hold to raise the footrest to upright position; release the button to stop.
Footrest Down	Press and hold to recline the footrest; release the button to stop.
Pause Button	Press this button to stop all the massage function.





Product Structure must be observed

Airbag Button	Press this button to cycle in sequence, foot & leg airbag,armrest airbag,shoulder airbag,airbag off.
Foot Roller Button	Press this button to turn on/off foot roller.
Heating	Press this button to turn on/off the heating function.
USB Port	Plug a USB cable into this interface for charging.





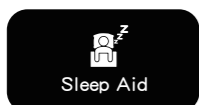

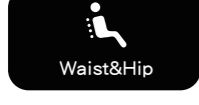
Controller



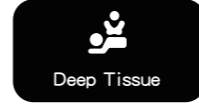
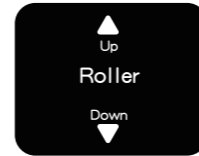

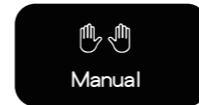

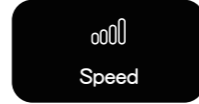
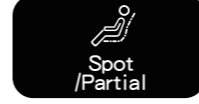
Product Structure must be observed

Function	Description
	On/Off Press this button, that is, to enter the boot state, run the "Relax" automatic massage program. In the power-on state, press this button again to turn off the power.
	Relax Massage strength is soft, Massage the whole body mainly by kneading & kowtowing.
	Fatigue Recovery Massage neck & back mainly by kneading & kowtowing & knocking. Massage strength from light to heavy.
	Thai Stretch Mainly backrest stretch with airbag squeeze to stretch muscle, promote blood circulation.
	Pain Relief Moderate massage. Massage neck & back mainly by kneading & acupressure & knocking. Through deep massage to achieve the effect of exercise. Suitable for groups with less movement.
	Sleep Aid Mainly by kneading & tapping to relax and help for sleeping. Suitable for people who don't sleep well.
	Neck Shoulder Massage neck & shoulder mainly by kneading, relieve pain of shoulder and neck, suitable for office worker.
	Waist & Hip Massage waist & hip mainly by kneading & acupressure to exercise spine and relax waist.

Product Structure must be observed

	Deep Tissue Massage strength is soft, Helps to rejuvenate muscles quickly and boost spirits.
	Roller Long-press key to move the movement up. Long-press key to move the movement down.
	Back Long-press key to raise the backrest. Long-press key to lower the backrest.
	Manual Press this button to enter the manual mode and switch massage techniques. There are six massage techniques, in order for kneading, kowtowing, acupressure, kneading & tapping, tapping, knocking. The 6 techniques display icon for 
	Speed Massage speed/Movement ejection key, 1. Press this key, adjust the movement massage speed, 3 adjustable strength. 2. Long-press key, the Indicator blinking, then adjust movement ejection, three adjustable strength. Long-press key again to turn off this function.
	Spot/Partial Press the fixed point/interval key, press this key, full name - fixed point - interval cycle in sequence.
	Width Adjustable in four manual modes of kowtowing, acupressure, kneading & tapping, knocking, wide - medium - narrow three grades.

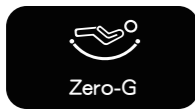
Product Structure must be observed

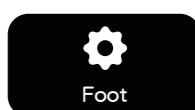
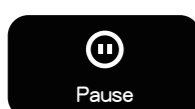
	Air Manual press this key, Arm airbag - shoulder airbag - leg foot airbag - airbag off, and so on in a cycle.
	Air Intensity Press this key, 1-3 gears cycle in sequence.
	Zero gravity Adjust the zero gravity gear: 1 gear - 2 gear-3 gear, in turn cycle.
	Heat Press this key to turn on or off the heat compress.
	Foot Press this key to sole scraping on/off and 3-speed adjustment of strength.
	Pause Press this key to pause all actions, press this key again to resume.

Bluetooth instructions

Play Mobile Music/Bluetooth speaker:

Turn on the Bluetooth on your mobile device, then select the Bluetooth device of the massage chair (FlexiSpot-MC058). Once paired, it can act as a speaker when the mobile phone is playing music. (Note: No password required)

Operations Instructions must be observed

ON/OFF Instructions

- Make sure the chair is in its original position before using it.
- Before sitting down, ensure that nothing is pinched between the armrest, backrest, and seat of the chair.
- Make sure there are no children, pets, or objects within the range of the backrest to avoid injury or damage.
- When adjusting the backrest, be careful of the gap between the backrest and the armrest.
- Empty your pockets and remove all jewelry and watches before using the chair.
- When the footrest is moving, please do not stand up or leave the seat, and don't stop the legrest's movement to avoid damaging the chair.

Turn on the power

- Plug the cord into the power supply socket.
- Plug the other end of the cord into a wall outlet.
- Turn the main power switch to " ON " position.

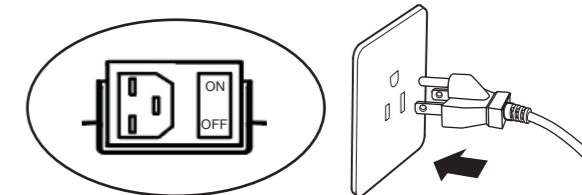

Turn off the power

- Double-check to ensure there are no people, pets, or objects within the range of the backrest and footrest.

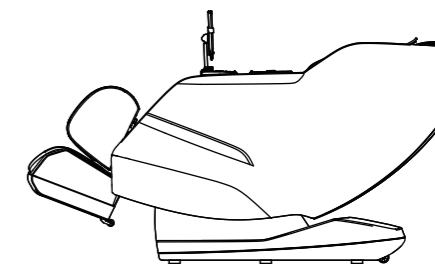

- Press  the controller to stop the massage and wait until the backrest and legrest return to their original positions.

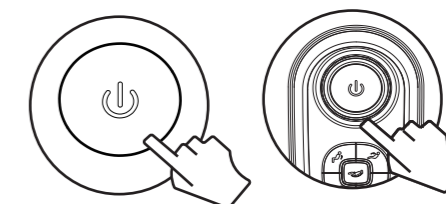

- To close the chair, press and hold the mechanical button on the armrest for about 1.5 seconds.

Operation Instructions must be observed

- Wait until the chair returns to its upright position.

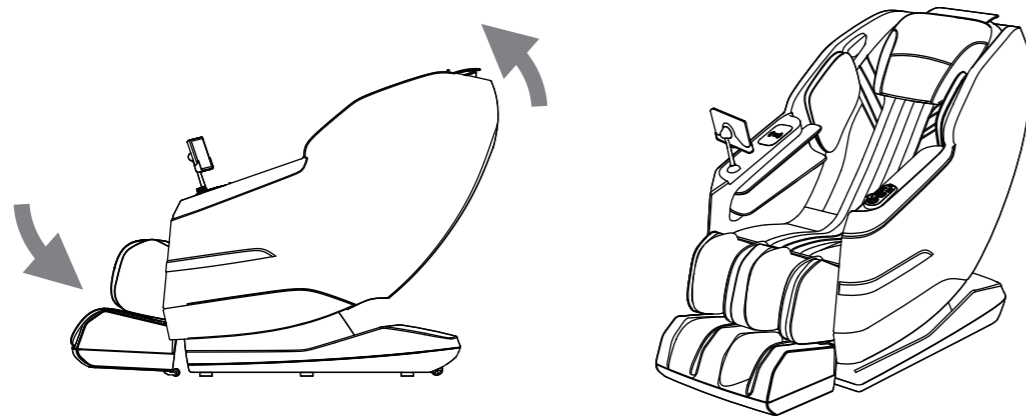

- Switch off the power.

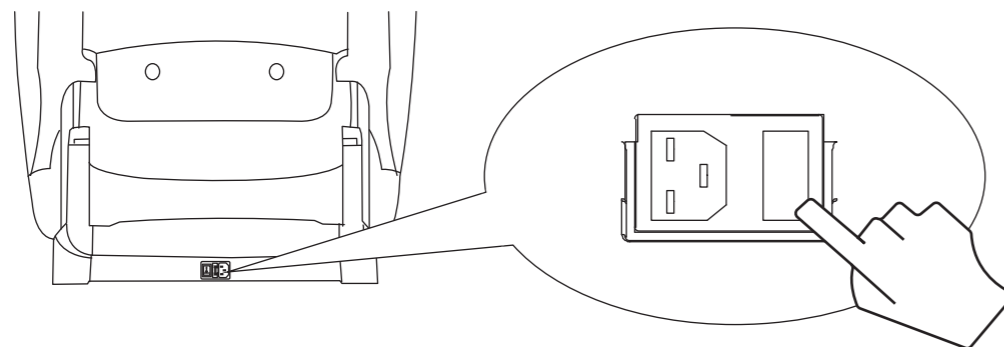

- Unplug the chair from the socket to prevent any unexpected harm to children or pets.

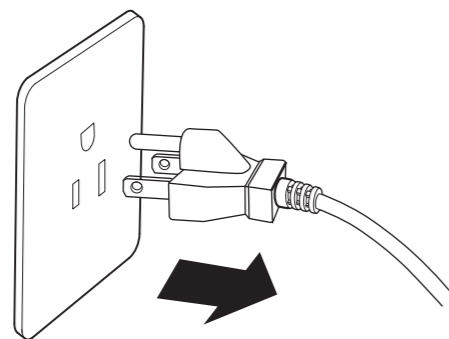

- Clean the chair if necessary.

Operation Instructions must be observed

This product must be grounded. If it malfunctions or breaks down, grounding provides a path of least resistance for electric current, reducing the risk of electric shock. This product is equipped with a cord that has an equipment-grounding conductor and a grounding plug. The plug must be inserted into an appropriate outlet that is properly installed and grounded in accordance with all local codes and ordinances.

DANGER : Improper connection of the equipment-grounding conductor can result in the risk of electric shock. If you are in doubt as to whether the product is properly grounded, consult a qualified electrician or service technician.

Do not modify the plug provided with the product—if it does not fit the outlet, have a proper outlet installed by a qualified electrician.

This product is for use on a nominal 110-volt circuit and has a grounding plug that looks like the plug illustrated in sketch A in the following figure. Make sure that the product is connected to an outlet having the same configuration as the plug. No adapter should be used with this product.

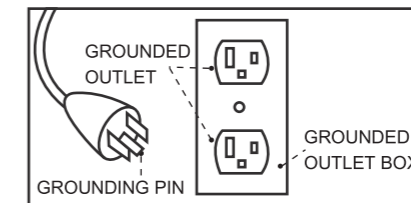

Earthing: This massage chair is classified as a Level One electrical appliance. Ensure that a three-pronged power supply socket is used, and verify that the ground wire of the socket has a proper connection to avoid electric leakage, electric shock, or other hazards during use.

Care and Maintenance must be observed

Storage

Power off the chair and unplug it from the power supply socket when not in use to prevent children from accidentally starting the chair.

Disconnect the controller and store the chair carefully if it will not be used for a long period. Do not disassemble the hook of the chair.

Keep the massage chair free of dust.

Cover the chair with a dust-free cloth to prevent dust accumulation. Do not store it in hot, humid, or damp places, or in direct sunlight or heat. Avoid storing it in extremely cold environments.

Maintenance

Before cleaning, unplug from the electrical source to avoid electric shock.

Care and Maintenance

must be observed

Synthetic Leather

General Cleaning:
Clean with a soft, dry cloth. (Chemical or medical cleaning products are prohibited.) If synthetic leather is dirty.

- Dip a soft cloth into a 3-5% neutral detergent solution, squeeze it, then gently clean the stain on the surface.
- Wash the cloth, squeeze it, and wipe with clean water.
- Dry gently with a clean, dry cloth.
- Allow to air dry—do not blow dry.

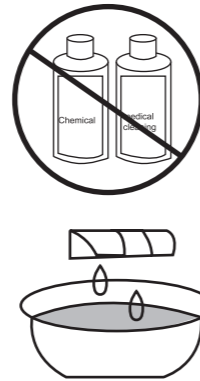

Fabric Material

- Dip a cloth into a weak neutral detergent, squeeze it, and clean the material surface. (Diluent, gas, and alcohol are prohibited.)
- Brush the dirty parts with a weak neutral detergent. (Avoid excessive brushing.)
- Excessive cleaning may damage the fabric material. Wipe with a water-dipped but squeezed cloth.
- Allow to air dry.

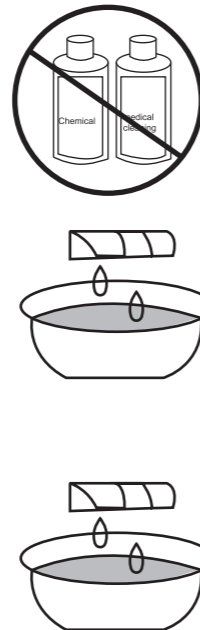

Plastic Parts

- Dip a cloth into a neutral detergent, squeeze it, and clean.
- Wipe with a water-dipped but squeezed cloth.
- Allow to air dry.

Clean the Controller

- Wipe with a soft cloth after squeezing out excess water.
- Allow to air dry.
- Propellant, diluent, or alcohol are prohibited.

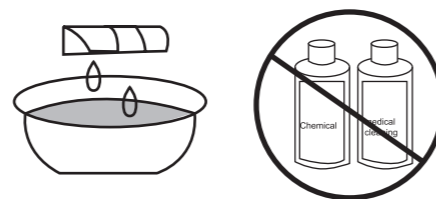

About Cleaning

- Before cleaning, unplug the chair from the electrical source to avoid electric shock. Do not touch the plug with wet hands.
- Ensure your hands are dry when plugging the chair into the socket.
- Failure to follow these instructions may result in electric shock.

Troubleshooting Guide

must be observed

Kind reminder

Please regularly check for the following issues:

- If there is Scorched smell.
- If power supply cord feels hot.
- Power is inconsistent (on sometimes, off sometimes) when touching the wire.
- Any other abnormal conditions.
- If any of the above occurs, please turn off the power supply and contact the distributor or manufacturer for assistance.

Troubleshooting guide

Problems/Issues	Possible Cause	Troubleshooting
Sounds like tapping or humming	Sounds from the air pump, motor, or other mechanical parts.	This is normal.
Sound suddenly becomes much louder	Long time of continuous use.	Turn off the power and let the massager rest for at least half an hour.
	Inner parts may be worn.	Contact customer service if the problem persists.
Abnormal sounds during operation	Possible overworking.	Cut down usage.
		Reduce usage and contact customer service.
Suddenly stops working	Normal.	Unplug and reinsert power cord to the chair.
	Auto program timer may have finished or bad power connection.	Normal. Restart the massage chair and increase massage time.
Does not work after power up	Power switch is not turned on.	Turn power switch on.
	Bad connection between plug and socket.	Connection power cord again.
	Massage remote is not turned on.	Press power button on the remote.
	Have broken power wire plug.	Contact our customer service team.
	Bad fuse.	Replace fuse.
Cannot recline	Obstruction-be sure that the chair is allowed enough room to fully recline.	Stop chair operation, and move obstruction.
		Contact our customer service team.

Troubleshooting Guide must be observed

Problems/Issues	Possible Cause	Troubleshooting
Backrest/legrest not moving	Obstacles in the way.	Remove obstacles and let the chair rest for half an hour before restarting.
		Contact our customer service team.
Unable to restore position after reclining	Excessive operation; Problem on electric motion pole or plug under bad connection.	Contact customer service.
Chair doesn't work after power-up	It may have overload.	Let the chair rest for at least half an hour. Contact customer service if the problem persists.
	Other abnormal case.	Contact our customer service team.
For other issues, please turn off the power supply and contact customer service.		

Product Specification must be observed

Description	Massage Chair
Model	OM300/OM301
Rated Input	110V~60Hz
Rated Power	150 W
Rated Working Time	Approx. 15 minutes (automatic power-off)
Dimension (LxWxH)	When it is tilting (L*W*H) 69.7*28.9*35.8* inches
	When it isn't tilting (L*W*H) 61.8*28.9*44.1* inches
Dimensions of packing box(LxWxH)	51.6*30.3*45.7* inches
Net Weight	Approx. 161 lbs
Gross Weight	Approx. 202 lbs

Product Specifications must be observed

Operating Conditions	Ambient temperature: Approx. 0°C -35°C
	Relative humidity: Approx. 20%-80%
Storage Conditions	Ambient temperature: Approx. -5°C -35°C
	Relative humidity: Approx. 20%-80%
Maximum body weight of user	Approx. 265lbs For a user heavier than 265lbs, the product may have louder noise and its fabric may be worn quicker.

Product Specifications must be observed

FCC Statement

Any changes or modifications not expressly approved by the party responsible for compliance could void the user's authority to operate the equipment. This device complies with part 15 of the FCC Rules. Operation is subject to the following two conditions:

- This device may not cause harmful interference.
- This device must accept any interference received, including interference that may cause undesired operation.

Expose Statement

This equipment complies with the FCC radiation exposure limits set forth for an uncontrolled environment. This transmitter must not be co-located or operating in conjunction with any other antenna or transmitter.

Note:

This equipment has been tested and found to comply with the limits for a Class B digital device pursuant to part 15 of the FCC Rules. These limits are designed to provide reasonable protection against harmful interference in a residential installation. This equipment generates, uses and can radiate radio frequency energy and, if not installed and used in accordance with the instructions, may cause harmful interference to radio communications.

However, there is no guarantee that interference will not occur in a particular installation. If this equipment does cause harmful interference to radio or television reception, which can be determined by turning the equipment off and on, the user is encouraged to try to correct the interference by one or more of the following measures:

- Reorient or relocate the receiving antenna.
- Increase the separation between the equipment and receiver.
- Connect the equipment into an outlet on a circuit different from that to which the receiver is connected.
- Consult the dealer or an experienced radio/TV technician for help.