

FlexiSpot

Note:

Before setup and operation, please read this user manual carefully and keep this manual for future reference.

AUTO INCLINE TREADMILL USER MANUAL

Model: WPM03B

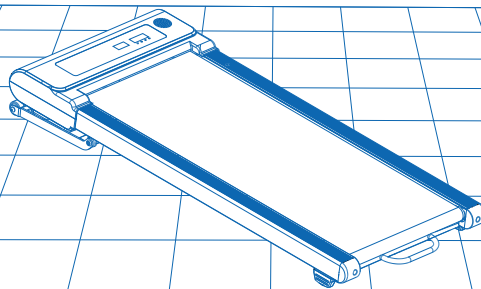

TABLE OF CONTENTS

1. IMPORTANT SAFETY INSTRUCTIONS-----	Page 1
2. SAFETY TIPS-----	Page 2
3. SPECIFICATION-----	Page 5
4. PRODUCT AND ACCESSORIES-----	Page 6
5. TREADMILL PARTS-----	Page 7
6. BEFORE START AND STORAGE-----	Page 8
7. SCREEN DISPLAY-----	Page 10
8. REMOTE CONTROL-----	Page 11
9. AUTOMATIC INCLINE-----	Page 13
10. PRESET PROGRAMS-----	Page 14
11. BLUETOOTH PAIRING-----	Page 15
12. TROUBLESHOOTING GUIDE-----	Page 16
13. CARE AND MAINTENANCE-----	Page 17
14. ERROR CODE-----	Page 19
15. WARRANTY-----	Page 20

1 IMPORTANT SAFETY INSTRUCTIONS

1. Ensure that you read the manual carefully before attempting to assemble or use the walking treadmill.
2. The walking treadmill is designed for indoor use only. It is not to be used outdoors.
3. Do not position the walking treadmill on a thick carpet as air needs to be able to circulate underneath.
4. Always wear the correct clothing when using the walking treadmill. Do not wear loose or long clothing as it may get caught in the moving belt.
5. Do not stand on the walking treadmill belt before operating. Position your feet on either side of the treadmill belt, and as the motor starts, step onto the treadmill. Do not step on the belt if the walking treadmill is at full speed.
6. Do not allow children or pets near the walking treadmill when in use.
7. Always unplug the walking treadmill from the main power supply when not in use.
8. Do not use your treadmill in wet, damp, or dusty areas as this can cause damage to the walking treadmill.
9. If any part of the electrical cable or plug is loose or becomes worn, do not use the walking treadmill. Have a qualified electrician inspect the problem.
10. The walking treadmill is not a toy and is not intended for use by persons (including children) with any physical or mental conditions. The walking treadmill should not be used by person who has not read and understood the manual.
11. If the user has had any prior medical condition, they should consult a doctor before use.
12. Store the treadmill indoors in a clean and dry area, away from direct sunlight, and ensure the main power switch is off and the power cord is unplugged from the power outlet.

2 SAFETY TIPS

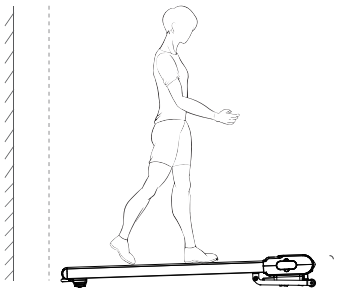

⚠ Keep a rear distance of 39 inches or more.

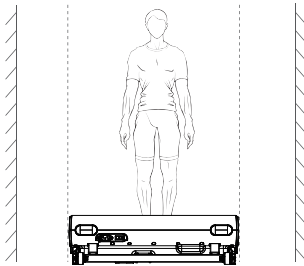

⚠ Keep a distance of 23.6 inches or more on both sides.

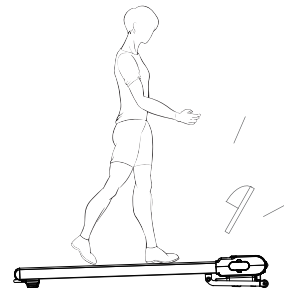

⚠ Wear sneakers when walking or running.

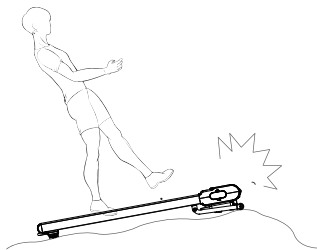

⊗ Do not use the treadmill on an uneven surface.

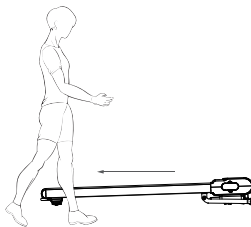

⊗ Do not hop on and off the treadmill when it is in use.

00:00

TIME SPEED DISTANCE CALORIE

⊗ Do not stand on the treadmill when it is calibrating automatically 4 seconds after starting up.

2 SAFETY TIPS



Elderly and pregnant users must be careful when using the treadmill.

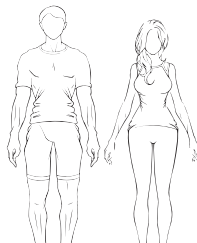

Ensure only one person uses the treadmill each time.

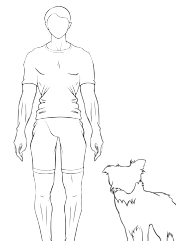

Do not use with pets.

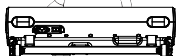

Do not walk or run sideways on the treadmill.

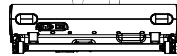

Do not walk or run backward on the treadmill.

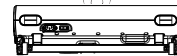

Children must be supervised when using the treadmill.

2 SAFETY TIPS

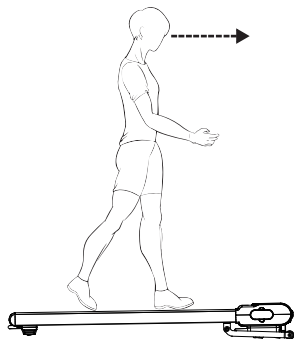

⚠ Look straight ahead to avoid dizziness



⊗ Do not trample on the treadmill.



⊗ Do not change the incline level of the treadmill by placing objects under treadmill.

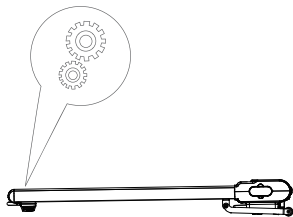

⚠ Ensure clothing and other small items are not caught inside the treadmill.

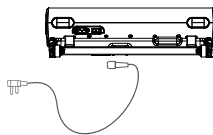

⚠ Unplug the power cord when not in use.



⊗ Do not store the treadmill in a sideways position.

3 SPECIFICATION

Performance Indicators	Detailed Parameters
Max. User Weight	275 lbs
	125 kg
Speed Range	0.6 - 4.0 MPH
Incline Range	2.5° - 7°
Walking Area	39.4 x 16.9 inches
	100 x 43 cm
Product Size	50.3 x 21.9 x 6.3 inches
	127.7 x 55.7 x 16.1 cm
Net Weight	56.9 lbs
	25.8 kg
Gross Weight	65.0 lbs
	29.5 kg
Power Rating	735 W
	1.0 HP
Voltage Rating	110 V
Recommended Ages For Use	14 - 60

4 PRODUCT AND ACCESSORIES

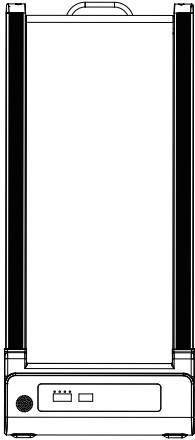

Treadmill x1



Allen Key x1



Lubricant x1

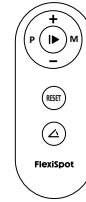

Remote Control x1

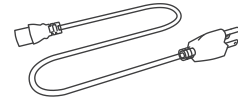

Power Cord x1

5 TREADMILL PARTS

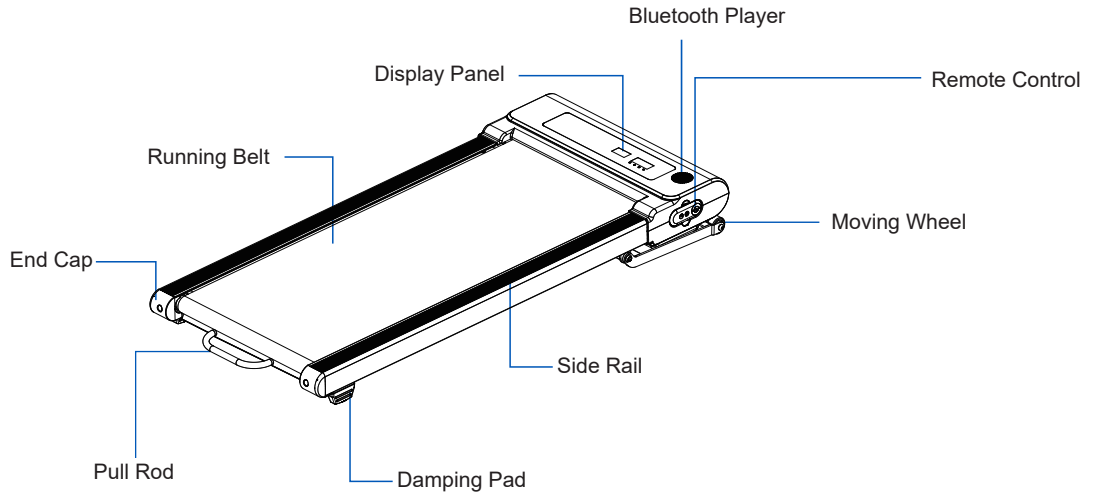

6 BEFORE START AND STORAGE

• Take out appliance from packages

1. Unbox and take out accessory bags.
2. Lift out appliance and place at flat surface.

Attention: 2-3 persons assist is necessary.

3. Its normal that visible welding marks residual on walk belt.

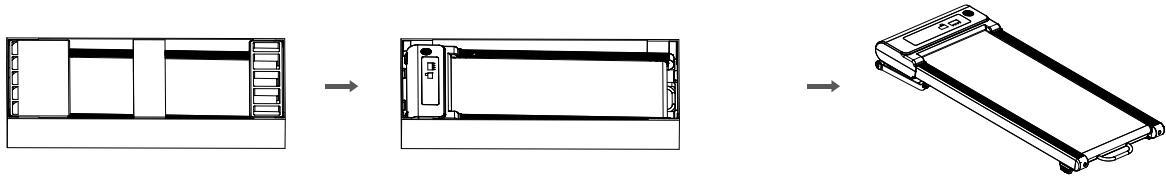

• Transportation

1. Pull out the power cord first before moving the treadmill around.
2. If the customer needs to move the device, first set the tilt angle to zero, then power off and move it. Easy to transport appliance with bottom transportation wheel assists, like as wheelbarrow.

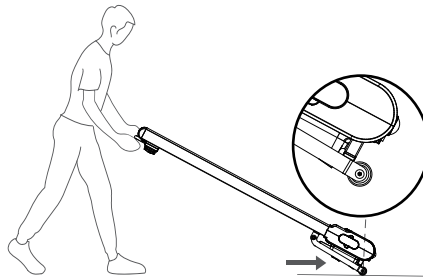

6 BEFORE START AND STORAGE

· Connect the power

1. Choose flat ground to place the Walking Treadmill. Do not place it on thick and soft cushion.
2. Plug in power cord and switch on power rock button, you can hear a Di sound from buzzer, its means the circuit of appliance has connected with power electricity.

Warning: MUST use power cord with comes of package.

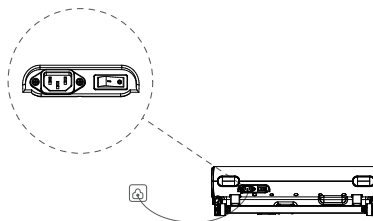
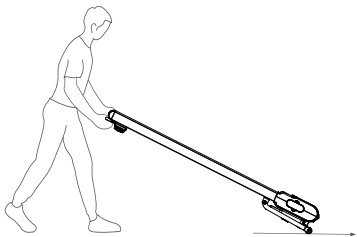

· Storage

Power off appliance and unplug power cord before storage process.

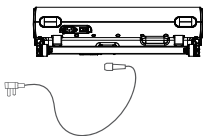

Warning:

Before starting to workout with this product, Please assess your physical condition and perform exercise properly and regularly. Incorrect or excessive training can be harmful to your health, If you feel unwell, Stop exercising immediately and consult with your doctor.

7 SCREEN DISPLAY



TIME

Display Time
0-99:59



SPEED

Display Speed
0.6-4.0 MPH



DISTANCE

Display Distance
0-99.9 miles



CALORIES

Display Calories
0-999 Kcal



INCLINE

Display Incline
1-9 level

DISPLAY FUNCTIONS:

TIME: Displays your elapsed workout time in minutes and seconds.







SPEED: Displays the current speed from a minimum of 0.6 MPH to a maximum of 4.0 MPH.

DISTANCE: Displays the accumulative distance traveled during workout.

CALORIES: Displays the total calories burned during your workout.

INCLINE: Displays automatic incline from level 1 to level 9.

8 REMOTE CONTROL

-  Start or pause the treadmill.
-  Increase the speed.
-  Decrease the speed.
-  Select the preset training program (P01-P06) before training.
-  Switch the display to set the time/distance/calories.
 - . Time range: 5 - 99 minutes.
 - . Distance range: 0.5 - 65.0 miles.
 - . Calories range: 10 -995 Kcal.
-  Stop the treadmill. "0" is displayed for both 2 display functions.
-  Automatic incline from level 1 to level 9.
 - . Level range: 2.5° - 7°.

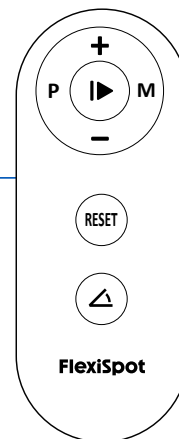
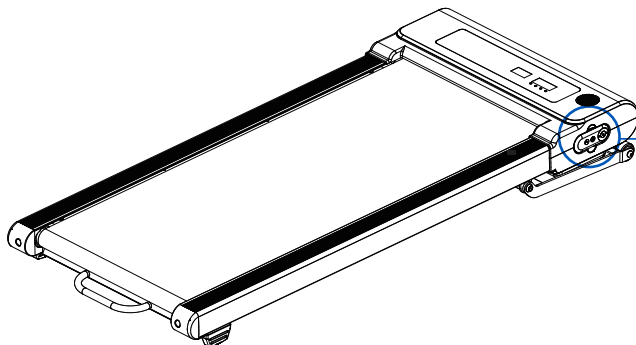

8 REMOTE CONTROL

REMOVE THE INSULATING PULL TAB BEFORE USE

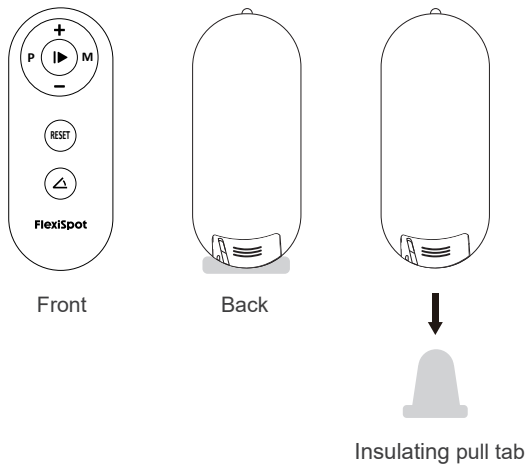

REPLACE BATTERY

STEP 1: Push then pull to remove the battery holder.

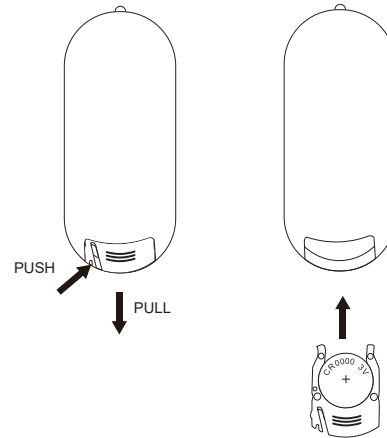

STEP 2: Remove the old battery and insert the new battery.



9 AUTOMATIC INCLINE

- 9 incline levels: 2.5° - 7°. Adjustable gear: 9 gear.
- Change the incline of working treadmill as desired.

• How to adjust incline angle?

The treadmill's default incline is set at 2.5°. To get started, press the  button, and once the treadmill is working, press the  button. When the incline reaches 7°, pressing the  button again will reset it back to 2.5°.



No Incline



Incline Level 1-9

• Friendly remind of automatic incline features

1. Incline level should be set to 2.5° with remote control when you are finished exercising.
2. Press the  button to identify incline level and back to 2.5° automatically.

10 PRESET PROGRAMS



P1: Walking Program



P2: Climbing Program 1



P3: Climbing Program 2



P4: Mountain Rd. Program



P5: Interval Program



P6: Jogging Program

PHASE SPEED PROG MPH	1	2	3	4	5	6	7	8	9	10	11	12	13	14	15	16	17	18	19	20
P1	0.6	1.3	1.3	1.3	1.9	1.9	1.9	1.3	1.3	1.3	1.9	1.9	1.9	1.3	1.3	1.3	1.9	1.9	1.9	0.6
P2	0.6	0.6	0.6	1.3	1.3	1.3	1.9	1.9	1.9	2.5	2.5	2.5	3.1	3.1	3.1	3.1	4.0	4.0	4.0	4.0
P3	0.6	0.6	1.3	1.3	1.9	1.9	2.5	2.5	3.1	4.0	4.0	3.1	2.5	2.5	1.9	1.9	1.3	1.3	0.6	0.6
P4	0.6	1.3	1.9	1.3	1.9	2.5	1.9	3.1	4.0	2.5	2.5	1.9	2.5	3.1	1.3	1.9	1.3	0.6	1.3	1.9
P5	1.3	1.3	0.6	0.6	1.9	1.9	0.6	0.6	2.5	2.5	0.6	0.6	3.1	3.1	0.6	0.6	4.0	4.0	0.6	0.6
P6	1.3	1.9	2.5	3.1	3.1	3.1	3.1	3.1	4.0	4.0	4.0	4.0	3.1	3.1	3.1	3.1	3.1	2.5	1.9	1.3

11 BLUETOOTH PAIRING

How to connect your phone to the treadmill's Bluetooth:

1. Access your phone's Bluetooth settings.
2. Pair with the network named "BTMP3".
3. If connected successfully, you will hear "Bluetooth is now connected".

Note: After the initial connection, your phone will automatically pair with the treadmill's Bluetooth in the future. To disconnect, simply return to your phone's Bluetooth settings and tap "Unpair", and you will hear "Bluetooth is now not connected".

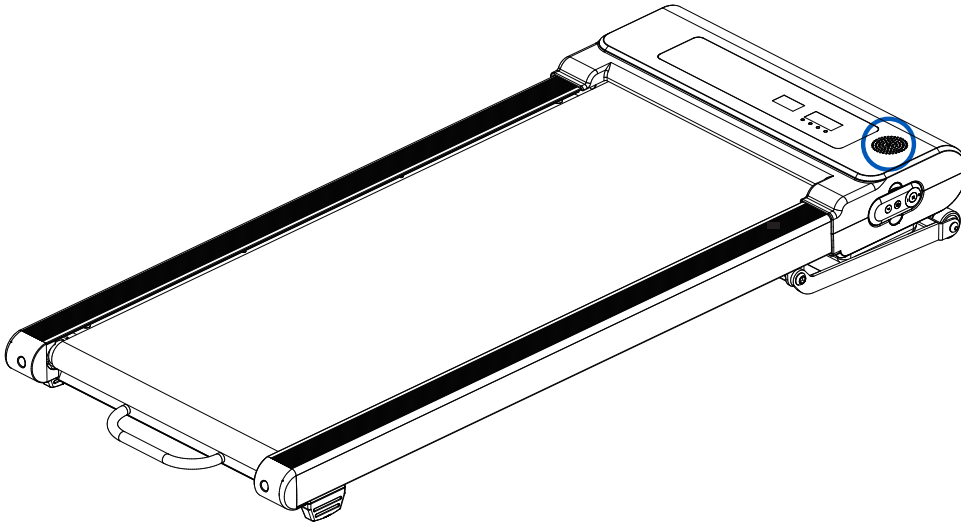

12 TROUBLESHOOTING GUIDE

Problem	Potential Causes	Corrections
The treadmill will not start.	<ol style="list-style-type: none"> 1. The treadmill is not plugged in. 2. The safety key is not attached to the treadmill console properly. 3. The circuit breaker in your house has tripped. 4. The circuit breaker in the treadmill has tripped. 	<ol style="list-style-type: none"> 1. Plug the power cord into a power outlet. 2. Reattach the safety key. 3. Call an electrician to replace the PCB for power supply. 4. Replace a new PCB for motor control.
The running belt slips.	The running belt is not tight enough.	Adjust the running belt's tension.
The running belt does not move when stepped on.	<ol style="list-style-type: none"> 1. The running deck lacks lubrication. 2. The running belt is too tight. 	<ol style="list-style-type: none"> 1. Apply some lubricant. 2. Adjust the running belt's tension.
The running belt is not centered.	The tension of the running belt at the rear conveyor roller is uneven.	Center the running belt.
The running belt stopped.	User weight over 265 lbs (120 kg).	Re-start the power switch, treadmill can be used again for any other people whose weight less than 265 lbs (120 kg).

13 CARE AND MAINTENANCE

A. ADJUSTING THE RUNNING BELT

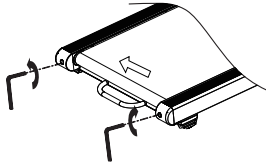

Figure A

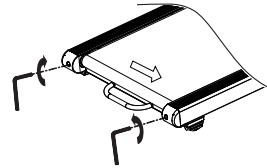

Figure B

B. CLEANING

1. Before moving or cleaning your Power Electric Treadmill, unplug it from the main power supply.
2. Always check the wear and tear of components like the V-belt and the running belt to prevent injury.
3. Clean the power switch and console with a soft dry cloth. **DO NOT USE A WET CLOTH ON THESE AREAS.**
4. Clean the Power Electric Treadmill with a damp cloth, avoiding the console. **DO NOT USE HARSH CLEANING AGENTS.**
5. After each workout, ensure that the treadmill is wiped clean.
6. The treadmill can be cleaned with a soft cloth and mild detergent. Do not use abrasives or solvents.
7. Be careful not to get excessive moisture on the display panel as this might damage the unit and create an electrical hazard.

14 CARE AND MAINTENANCE

C. LUBRICATION

1. Lubricating the bottom of the running belt will ensure superior performance and extend the belt's life expectancy. After the first 25 hours of use (or 2 to 3 months), apply some lubricant and repeat following every 50 hours of use (or 5 to 8 months).

2. How to check the running belt for proper lubrication

Lift one side of the running belt and touch the top surface of the running deck. If the surface is slick to the touch, then no further lubrication is required. If the surface is dry to the touch, apply some lubricant.

3. How to apply lubricant

Lift one side of the running belt. Pour some lubricant under the center of the running belt on the top surface of the running deck.

4. Jog on the treadmill at a slow speed for 3 to 5 minutes to distribute the lubricant evenly.

NOTE: DO NOT over-lubricate the running deck. Any excess lubricant that leaks out should be wiped off.



Lubricant

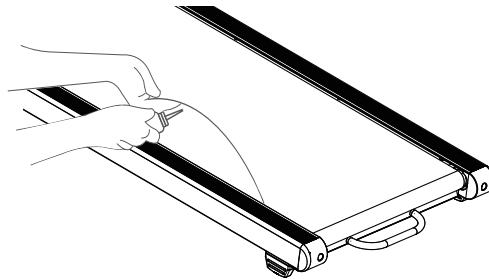

15 ERROR CODE

Error Code	Description	Solution
ER01	Signal loss in PCBs 1. When the light on the main PCB flashes rapidly, it means the display panel's PCB cannot receive signals from the main PCB. 2. When the light on the main PCB flashes slowly, it means the main PCB cannot receive signals from the display panel's PCB.	1. Reset the treadmill. If the error persists and the light on the main PCB flashes rapidly, replace the display panel's PCB. 2. Reset the treadmill. If the error persists and the light on the main PCB flashes slowly, replace the main PCB.
ER04	Abnormal AC input voltage	Reset the treadmill. If the error persists, check your power supply. If the voltage is abnormal, wait for your power supply to stabilize first before using the treadmill again.
ER05	Stall protection (MOS)	Reset the treadmill. If the error persists, replace the main PCB.
ER06	Open circuit in main motor	Reset the treadmill. If the error persists, replace the main motor.
ER07	Motor overload	Add lubricant and reset the treadmill. If the error persists, replace both the main PCB and the main motor.
ER08	Short circuit in main motor	Reset the treadmill. If the error persists, replace the main motor.
ER10	Malfunction of incline sensor (Failure of potentiometer)	Reset the treadmill. If the error persists, replace the lift motor.

16 WARRANTY

MANUFACTURER'S LIMITED WARRANTY

FlexiSpot warrants to the original purchaser that this product is free from defects in material and workmanship when used for the intended purpose, under the condition that it has been installed and operated in accordance with the provided user manual. FlexiSpot's obligation under this warranty applies to the following:

LENGTH OF WARRANTY

2 years.

Exclusions from Warranty Coverage

FlexiSpot does not warrant against, and is not responsible for (and no implied warranty shall be deemed to cover) any product failure, product malfunction, or damages attributable to:

1. Improper installation and/or failure to abide by FlexiSpot's setup guidelines;
2. Use of this product beyond normal home use or in an application for which it was not designed;
3. Cosmetic items such as scratches, dents, or discolorations;
4. Damage caused by normal wear and tear, vandalism, accidents, or by animals;
5. Any act of nature (such as fire, flooding, snow, ice, hurricanes, earthquakes, lightning, or other natural disasters), environmental conditions (such as air pollution, mold, mildew, etc.), or staining from foreign substances (such as dirt, grease, oil, etc.);
6. Normal weathering due to exposure to sunlight, weather, and atmosphere, which can cause colored surfaces to, among other things, flake, chalk, accumulate dirt, or stain;
7. Improper operation, alteration, handling, storage, abuse, or neglect of the products.

FlexiSpot, at its sole discretion, will either repair or replace, free of charge, any part(s) proven to be defective under normal home use. Any repair or replacement shall not extend the original warranty period but shall retain only the remaining portion of the original product's warranty.

This warranty is offered only to the original purchaser and is not transferable. Proof of original purchase is required.

When ordering replacement parts, please have the following information ready:

1. **Order Number**
2. **Description of Parts (adding photos or videos would be helpful)**
3. **Part Number**
4. **Date of Purchase**

Website: www.flexispot.com
Tel: 1-855-585-5618